

LOAD RATINGS		
RATING	lbf	Newtons
RADIAL BASIC DYNAMIC	8,090	35,986
MAXIMUM STATIC CAPACITY	21,140	94,035

MS NO. _____ NSN NO. _____ DRAWING NO. YNB-72

ISO VIEW
SCALE .750:1

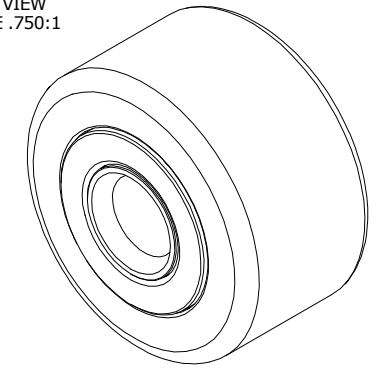

- NOTES:
- BEARING IS PACKED WITH NLGI GRADE 2, LITHIUM BASED GREASE (UNLESS OTHERWISE SPECIFIED)
 - ALL EXPOSED SURFACES HAVE BLACK OXIDE
 - LIMITING SPEED:
 - GREASE = 1,400 RPM

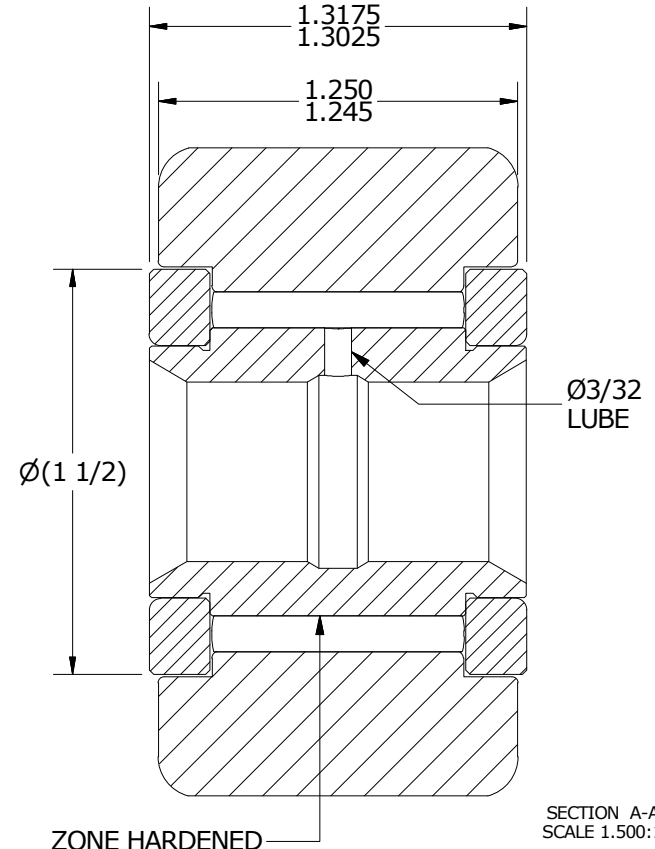
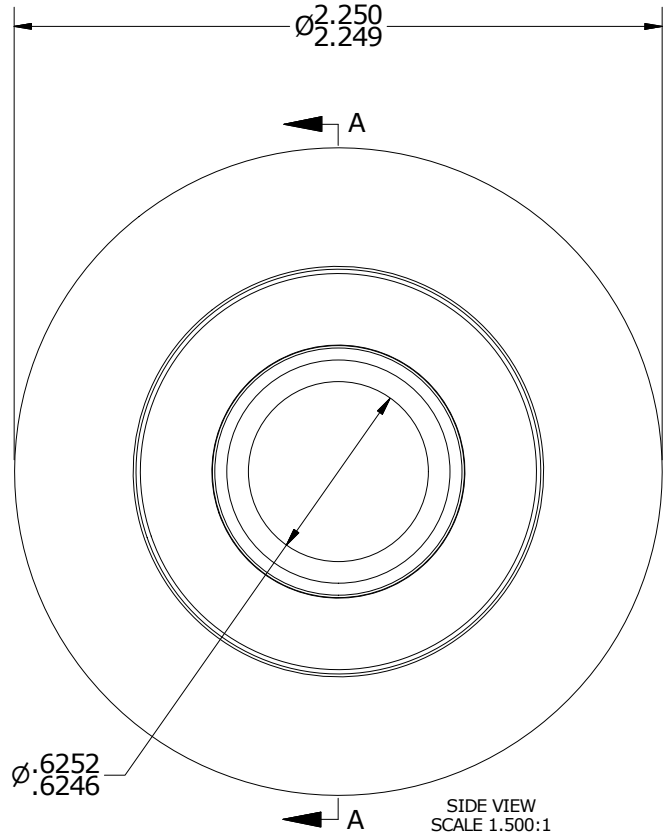

Recommended Shaft Fits		
Fit Type - Dimension	Ø (Inch)	Ø (mm)
Push - Max	.6247	15.6874
Push - Min	.6243	15.8572
Drive - Max	.6253	15.8826
Drive - Min	.6249	15.8725
Press - Max	.6257	15.8928
Press - Min	.6253	15.8826

MATERIAL NOTES:

OUTER RING- BEARING STEEL, HEAT TREATED
 INNER RING- BEARING STEEL, ZONE HARDENED
 NEEDLE ROLLER(S) - BEARING STEEL, HEAT TREATED
 WASHER(S) - BEARING STEEL, HEAT TREATED
 SEAL(S) - SYNTHETIC

CUSTOMER PART#	XX = ± .01 XXX = ± .005 XXXX = ± .0005 ANGLES = ± 1' INCH [METRIC] FRACTION = ± 1/32
ENGINEERING CHANGE ORDER NOTE	

CARTER MANUFACTURING IS NOT RESPONSIBLE FOR TYPOGRAPHICAL ERRORS	
REVISION	
B	AUTHOR BY HG
REVISION BY SGW	DATE 7/19/2018

CARTER MANUFACTURING CO., INC. GRAND HAVEN, MICHIGAN 49417			
PART NAME: ASSEMBLY			PRODUCT TYPE: CNB/YNB
DRAWN BY EMD	CHK'D BY MD	SALES KR	MATERIAL NOTED
DATE 8/4/2006	DATE 7/19/2018	DATE 7/19/2018	SHEET 1 OF 2