

LOAD RATINGS		
RATING	lbf	Newton
RADIAL BASIC DYNAMIC	2,225	9,897
MAXIMUM STATIC CAPACITY	6,120	27,223

- NOTES:
- BEARING IS PACKED WITH NLGI GRADE 2, LITHIUM BASED GREASE (UNLESS OTHERWISE SPECIFIED)
 - ALL EXPOSED SURFACES AS MOUNTED HAVE BLACK OXIDE
 - LIMITING SPEED:
 - A. GREASE = 3,400 RPM
 - CUSTOM LASER ETCHING UPON REQUEST

ISO VIEW
SCALE 1.563 : 1

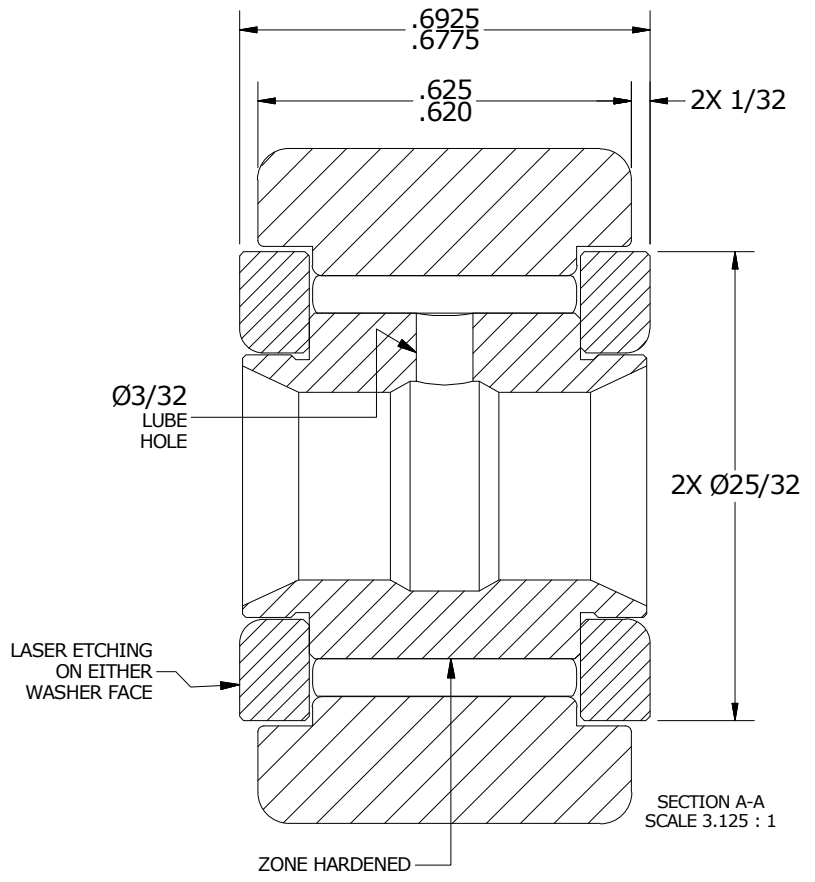
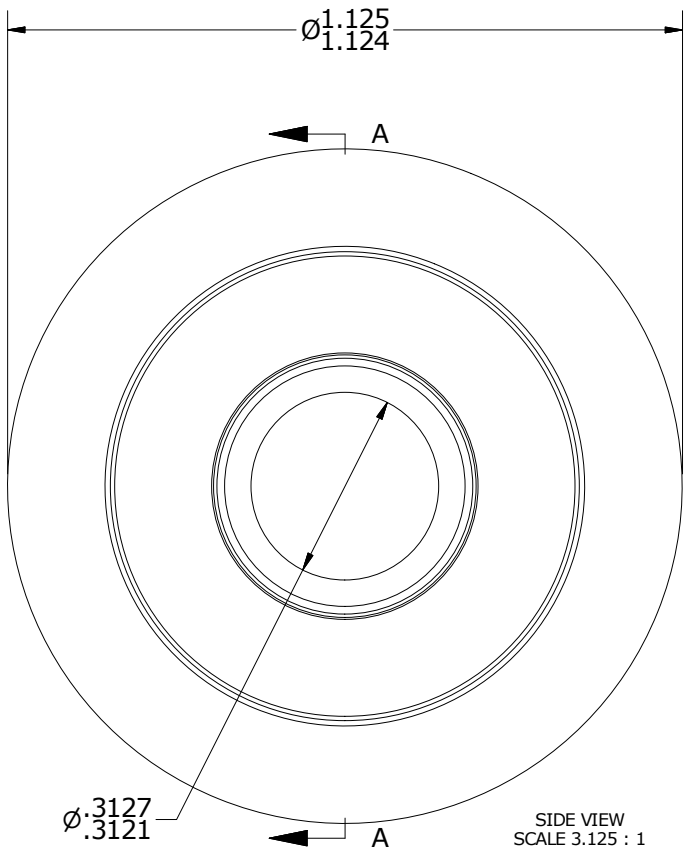
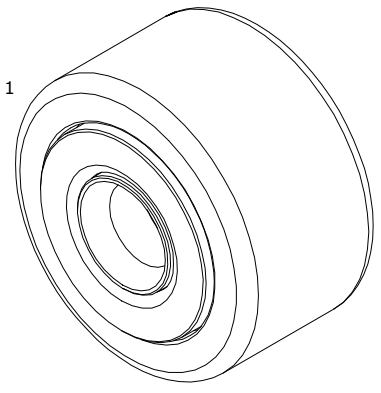

Recommended Shaft Fits		
Fit Type - Dimension	Ø (Inch)	Ø (mm)
Push - Max	.3122	7.9300
Push - Min	.3118	7.9197
Drive - Max	.3128	7.9451
Drive - Min	.3124	7.9350
Press - Max	.3130	7.9502
Press - Min	.3126	7.9400

MATERIAL NOTES:

OUTER RING- BEARING STEEL, HEAT TREATED
 INNER RING- BEARING STEEL, ZONE HARDENED
 NEEDLE ROLLER(S) - BEARING STEEL, HEAT TREATED
 WASHER(S) - BEARING STEEL, HEAT TREATED

CUSTOMER PART#	XX = ± .01 XXX = ± .005 XXXX = ± .0005 ANGLES = ± 1' INCH [METRIC] FRACTION = ± 1/32
ENGINEERING CHANGE ORDER NOTE	

CARTER MANUFACTURING IS NOT RESPONSIBLE FOR TYPOGRAPHICAL ERRORS	
REVISION	
D	AUTHOR BY DB
REVISION BY SGW	DATE 5/6/2013

CARTER MANUFACTURING CO., INC. GRAND HAVEN, MICHIGAN 49417				PART NAME: ASSEMBLY		PRODUCT TYPE: CNB	
DRAWN BY EMD	CHK'D BY MD	SALES KR	MATERIAL NOTED	DATE 8/4/2006	DATE 5/6/2013	DATE 5/6/2013	SHEET 1 OF 2