

LOAD RATINGS

RATING	lbf	Newtons
DYNAMIC LOAD RATING	1,850	8,229
STATIC THRUST LOAD	480	2,135
STATIC RADIAL LOAD	780	3,470

NOTES:

1. BALL BEARINGS COME PRE-PACKED WITH GREASE.
2. THE OUTER RING SHALL BE INSTALLED SO THE O.D. CORNER WITH THE 1/32 X 45° CHAMFER IS ON THE SAME SIDE AS THE INNER RING FLANGE FACE (AS SHOWN).
3. OUTER RING, RETAINING RING GROOVE CONFORMS TO DIN 472.
4. OUTER RING, INNER RING & WASHER: ALL EXPOSED SURFACES HAVE BLACK OXIDE.
5. CUSTOM LASER ETCHING AVAILABLE UPON REQUEST

MS NO.

NSN NO.

DRAWING NO.

VHRY-250-A

ISO VIEW
SCALE .688 : 1

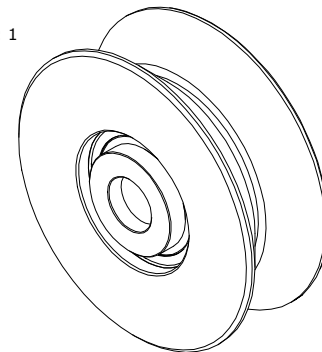

SIGNED DRAWING APPROVAL REQUIRED

PLEASE REVIEW AND VERIFY INFORMATION ON ALL SHEETS & RETURN COPY WITH SIGNED AND DATED APPROVAL, AND/OR REQUIRED CHANGES. CARTER WILL NOT PROCEED WITH ORDER UNTIL APPROVAL IS RECEIVED

SIGNED _____

DATE _____

APPROVED

REJECTED

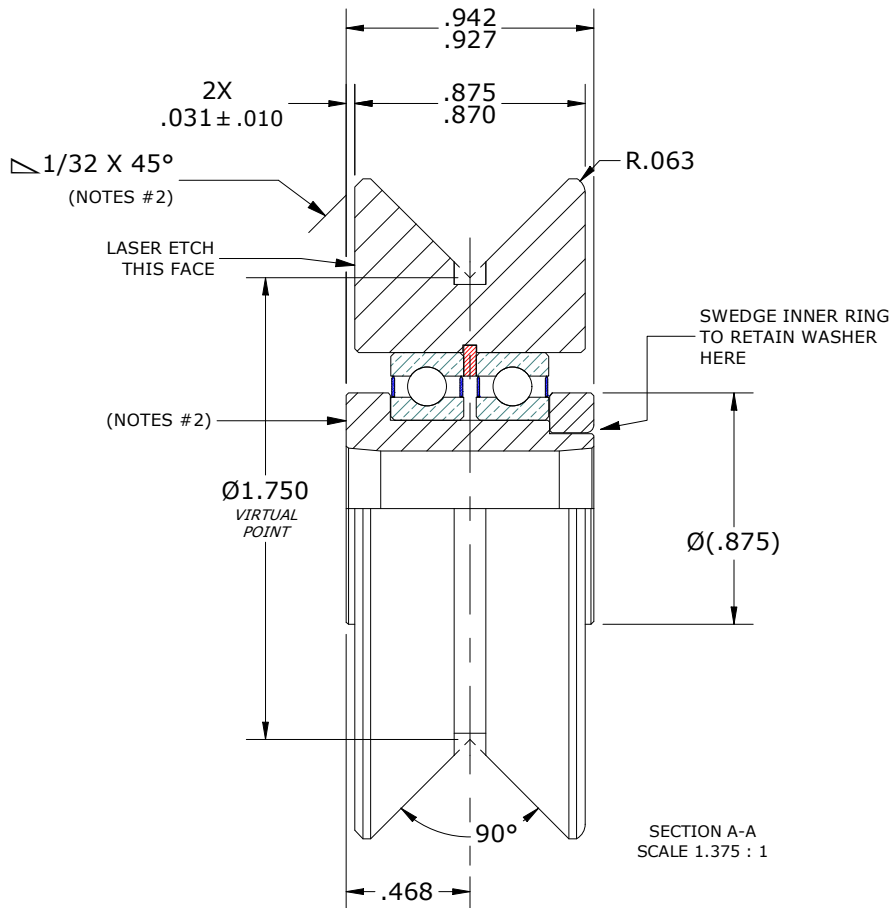
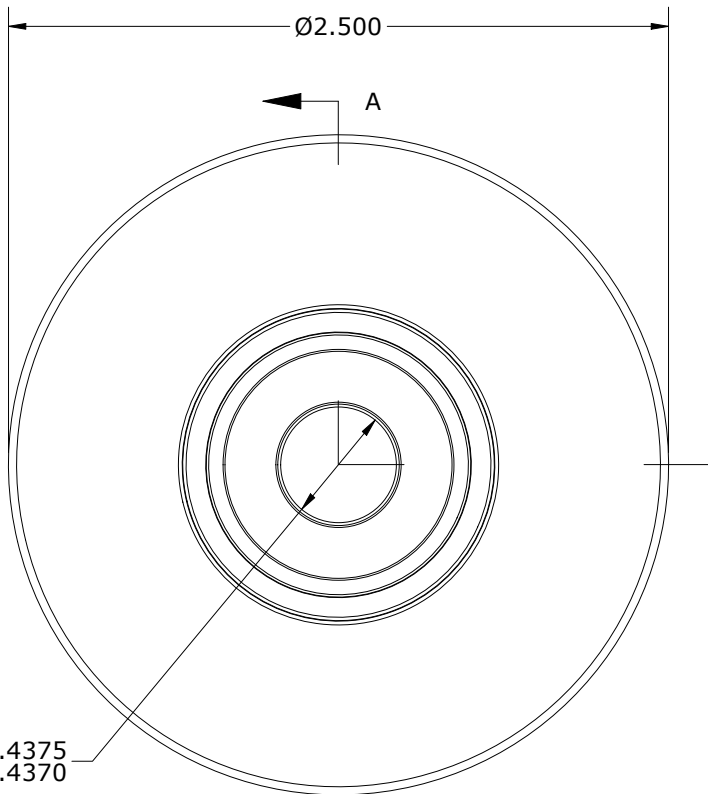

SECTION A-A
SCALE 1.375 : 1

MATERIAL NOTES:

- OUTER ROLLER HOUSING - BEARING STEEL, HEAT TREATED
- YOKE - STEEL
- WASHER - STEEL
- BALL BEARING(S) - 6903 2RS (17mm X 30mm x 7mm)
- RETAINING RING - DHO-30 OR EQUIVALENT

CUSTOMER PART#

XX = ± .01
XXX = ± .005
XXXX = ± .0005
ANGLES = ± 1'
INCH [METRIC]
FRACTION = ± 1/32

CARTER MANUFACTURING IS NOT RESPONSIBLE FOR TYPOGRAPHICAL ERRORS

CARTER MANUFACTURING CO., INC.

GRAND HAVEN, MICHIGAN 49417

ENGINEERING CHANGE ORDER NOTE

REVISION

PART NAME: ASSEMBLY

PRODUCT TYPE: VHRY

B

AUTHOR BY
HG

DRAWN BY
SGW

CHK'D BY
MD

SALES
NC

MATERIAL
NOTED

REVISION BY
SGW

DATE
3/8/2021

DATE
8/22/2018

DATE
3/5/2021

DATE
3/10/2021

SHEET
1 OF 2