

LOAD RATINGS	
RATING	Lbs
RADIAL BASIC DYNAMIC	9,376
MAXIMUM STATIC CAPACITY	26,320

NOTES:  
 1. BEARING COMES PACKED WITH CARTER STANDARD H1 FOOD GRADE GREASE

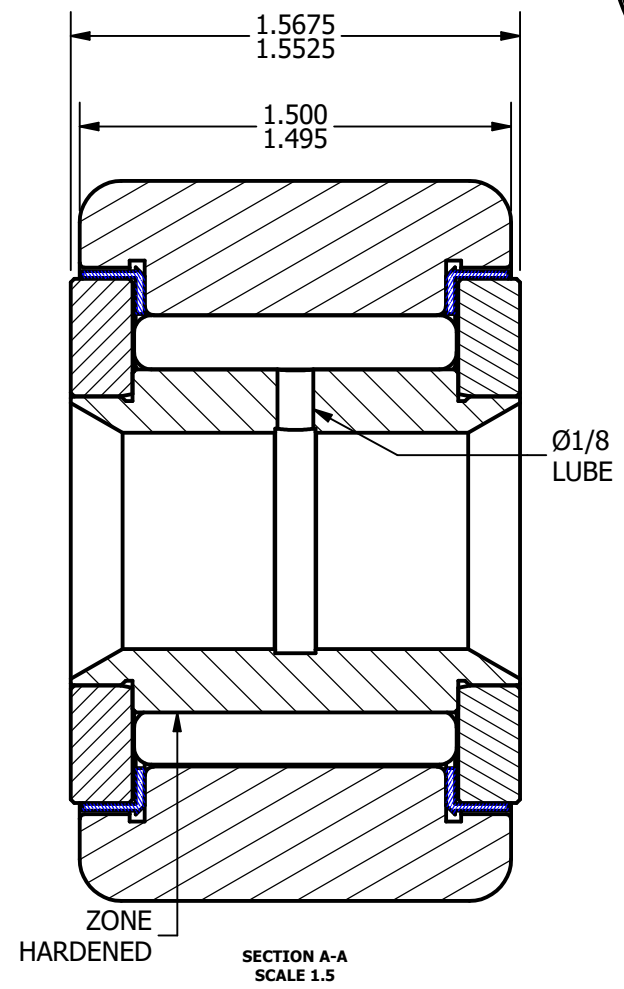
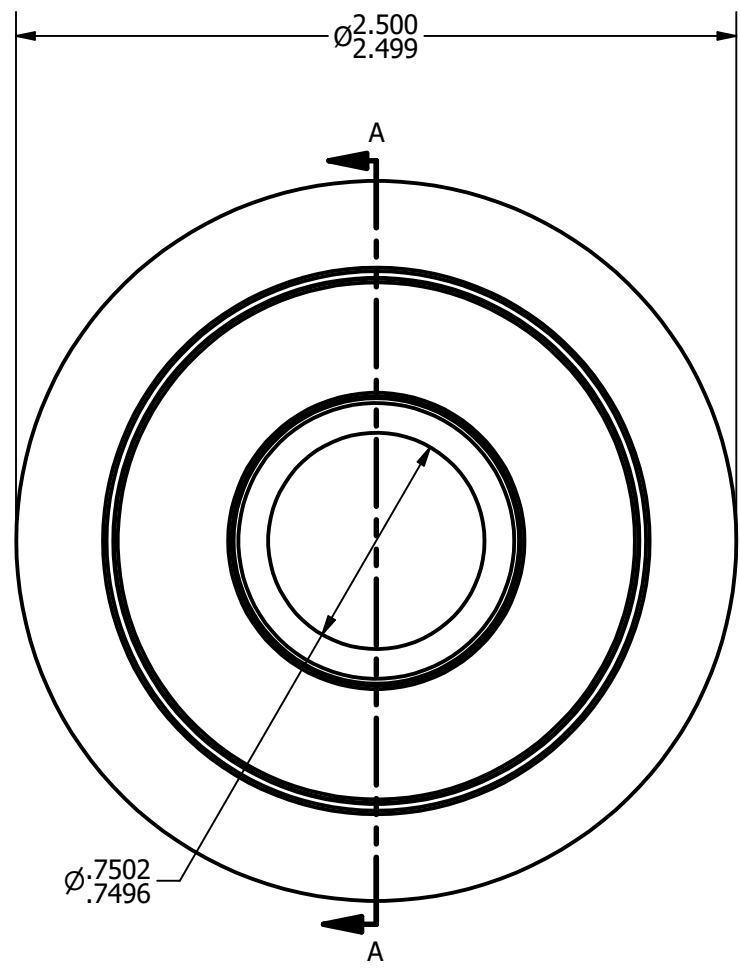
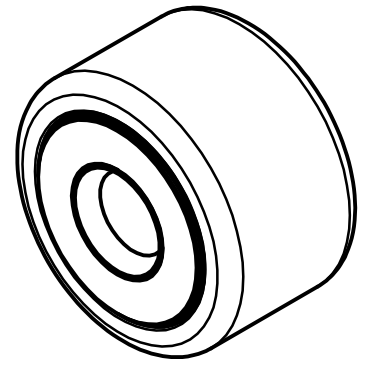

**MATERIAL NOTES:**  
 OUTER - 440c STAINLESS STEEL, HEAT TREATED  
 STUD - 440c STAINLESS STEEL, ZONE HARDENED  
 ROLLERS - 440c STAINLESS STEEL, HEAT TREATED  
 WASHERS - 440c STAINLESS STEEL, HEAT TREATED  
 SEALS - SYNTHETIC

CUSTOMER PART#	.XX = ± .01 .XXX = ± .005 .XXXX = ± .0005 ANGLES = ± 1' INCH [METRIC]
CHANGE NOTE:	
UPDATED TO INVENTOR FORMAT & ADDED ASSEMBLY INSPECTION DIMENSIONS PER ECO #3153	

CARTER MANUFACTURING IS NOT RESPONSIBLE FOR TYPOGRAPHICAL ERRORS

REVISION	
<b>B</b>	<b>AUTHOR. BY</b> DB
<b>REV. BY</b> MD	<b>DATE</b> 1/30/2009

**CARTER MANUFACTURING CO., INC.**  
 GRAND HAVEN, MICHIGAN 49417

PART NAME: ASSEMBLY		SHEET 1 OF 2			
<b>REVISION</b>	<b>DRAWN BY</b> GJP	<b>CHK'D BY</b> SGW	<b>SALES</b> KR	<b>MATERIAL</b> NOTED	<b>DRAWING NO.</b> SY-80-S
	<b>DATE</b> 4/13/2000	<b>DATE</b> 1/30/2009	<b>DATE</b> 1/30/2009		