

LOAD RATINGS		
RATING	lbf	Newtons
RADIAL BASIC DYNAMIC	6,472	28,789
MAXIMUM STATIC CAPACITY	16,912	75,228

NOTES:
 1. BEARING IS PACKED WITH NLGI GRADE 2, FOOD GRADE H1 GREASE (UNLESS OTHERWISE SPECIFIED)

MS NO. _____ NSN NO. _____ DRAWING NO. SY-64-S

ISO VIEW
SCALE .813 : 1

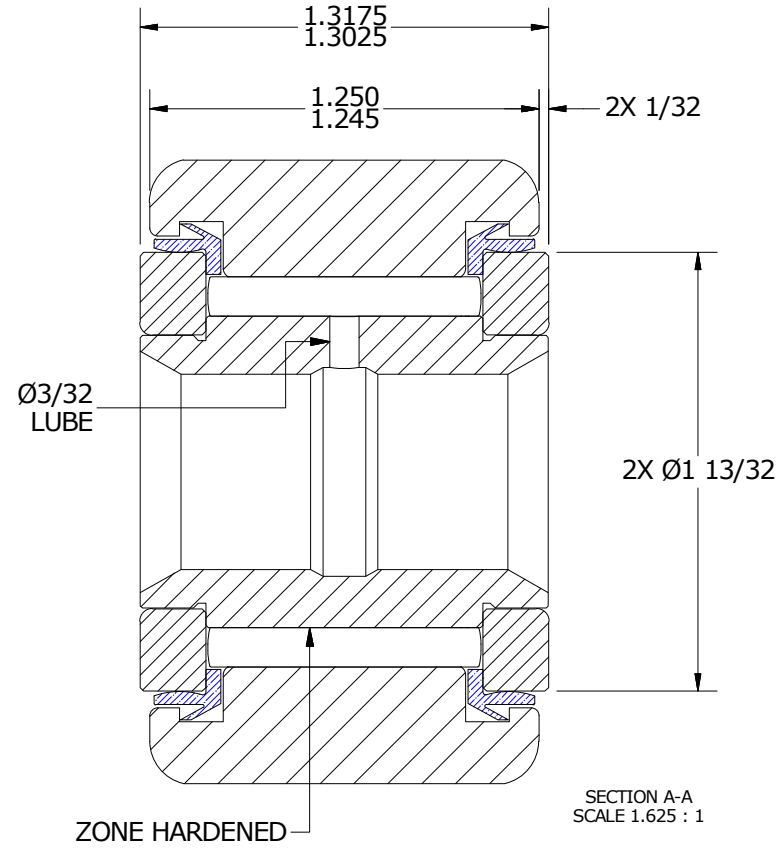
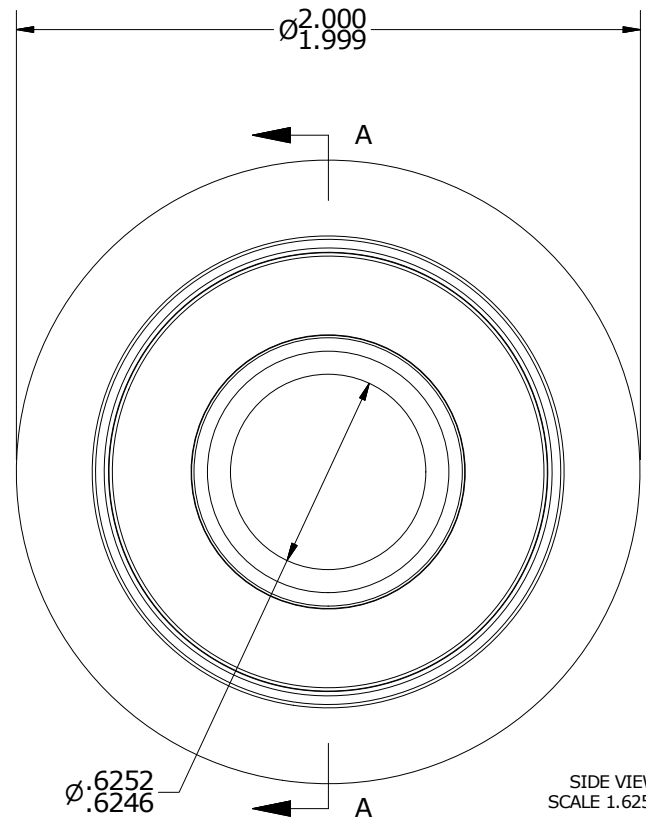
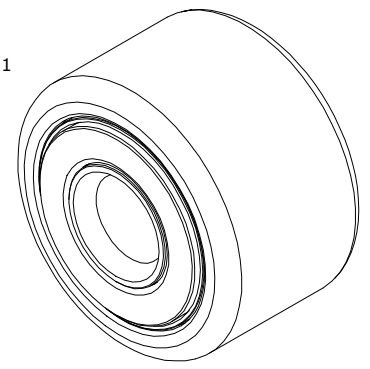

Recommended Shaft Fits		
Fit Type - Dimension	Ø (Inch)	Ø (mm)
Push - Max	.6247	15.8674
Push - Min	.6243	15.8572
Drive - Max	.6253	15.8826
Drive - Min	.6249	15.8725
Press - Max	.6257	15.8928
Press - Min	.6253	15.8826

MATERIAL NOTES:
 OUTER RING - 440C STAINLESS STEEL, HEAT TREATED
 INNER RING - 440C STAINLESS STEEL, ZONE HARDENED
 NEEDLE ROLLER(S) - 440C STAINLESS STEEL, HEAT TREATED
 WASHER(S) - 440C STAINLESS STEEL, HEAT TREATED
 SEAL(S) - SYNTHETIC

CUSTOMER PART# _____
 XX = ± .01
 XXX = ± .005
 XXXX = ± .0005
 ANGLES = ± 1'
 INCH [METRIC]
 FRACTION = ± 1/32

CARTER MANUFACTURING IS NOT RESPONSIBLE FOR TYPOGRAPHICAL ERRORS

CARTER MANUFACTURING CO., INC.
 GRAND HAVEN, MICHIGAN 49417

REVISION		PART NAME: ASSEMBLY		PRODUCT TYPE: CNB / SC	
B	AUTHOR BY HG	DRAWN BY GJP	CHK'D BY MD	SALES KR	MATERIAL NOTED
REVISION BY SGW	DATE 7/27/2018	DATE 7/9/1999	DATE 7/27/2018	DATE 7/27/2018	SHEET 1 OF 2