

- NOTES:  
 1. BUSHING IS IMPREGNATED WITH OIL  
 2. ALL EXPOSED STEEL SURFACES HAVE BLACK OXIDE

MS NO.

NSN NO.

DRAWING NO.

SFHE-32-A

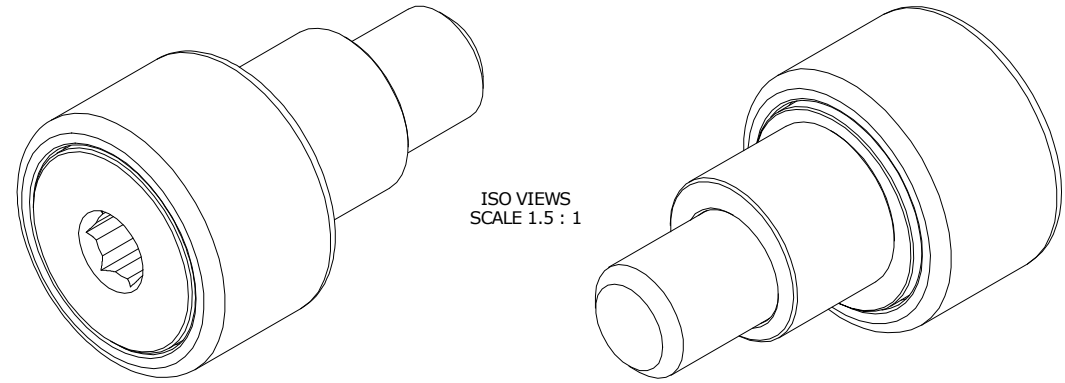

ISO VIEWS  
 SCALE 1.5 : 1

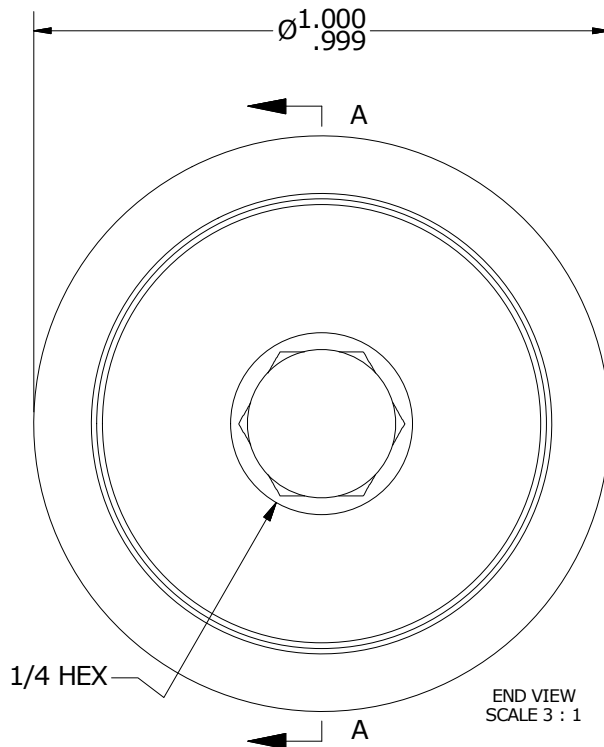

END VIEW  
 SCALE 3 : 1

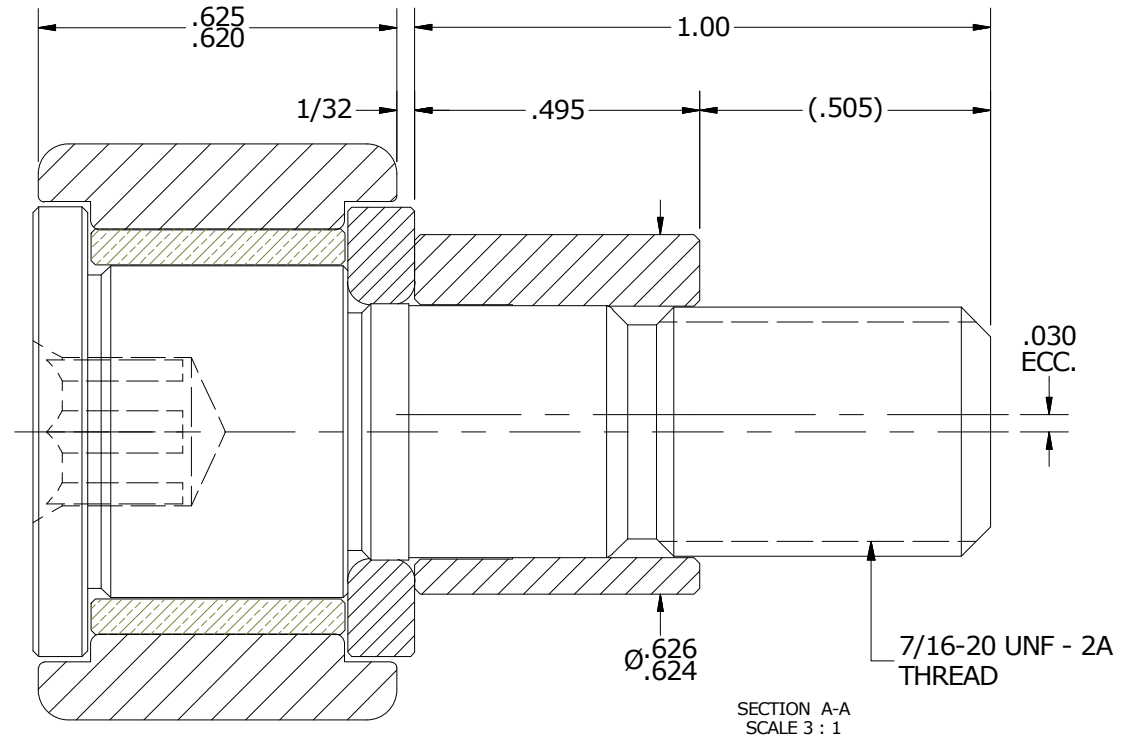

SECTION A-A  
 SCALE 3 : 1

MATERIAL NOTES:

- OUTER RING - BEARING STEEL, HEAT TREATED
- STUD - COLD ROLLED STEEL
- BUSHING - SINTERED BRONZE
- WASHER - BEARING STEEL, HEAT TREATED
- ECCENTRIC SLEEVE - COLD ROLLED STEEL

CUSTOMER PART#

XX = ± .01  
 XXX = ± .005  
 XXXX = ± .0005  
 ANGLES = ± 1'  
 INCH [METRIC]  
 FRACTION = ± 1/32

CARTER MANUFACTURING IS  
 NOT RESPONSIBLE FOR  
 TYPOGRAPHICAL ERRORS

**CARTER MANUFACTURING CO., INC.**

GRAND HAVEN, MICHIGAN 49417

ENGINEERING CHANGE ORDER NOTE

REVISION

PART NAME: ASSEMBLY

**A**

AUTHOR BY  
 HG

DRAWN BY  
 SGW

CHK'D BY  
 MD

SALES  
 KR

MATERIAL  
 NOTED

REVISION BY  
 SGW

DATE  
 1/2/2017

DATE  
 12/13/2016

DATE  
 12/21/2016

DATE  
 12/21/2016

SHEET  
 1 OF 2