

NOTES:

- 1. BUSHING IS IMPREGNATED WITH OIL
- 2. ALL EXPOSED STEEL SURFACES HAVE BLACK OXIDE

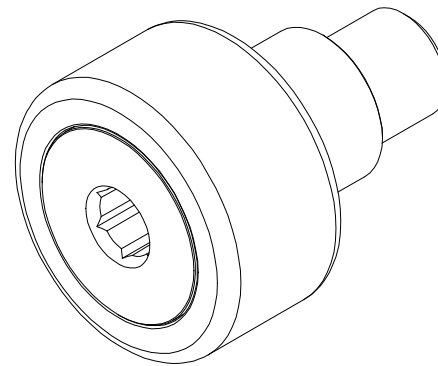

ISO VIEWS
SCALE 1/2

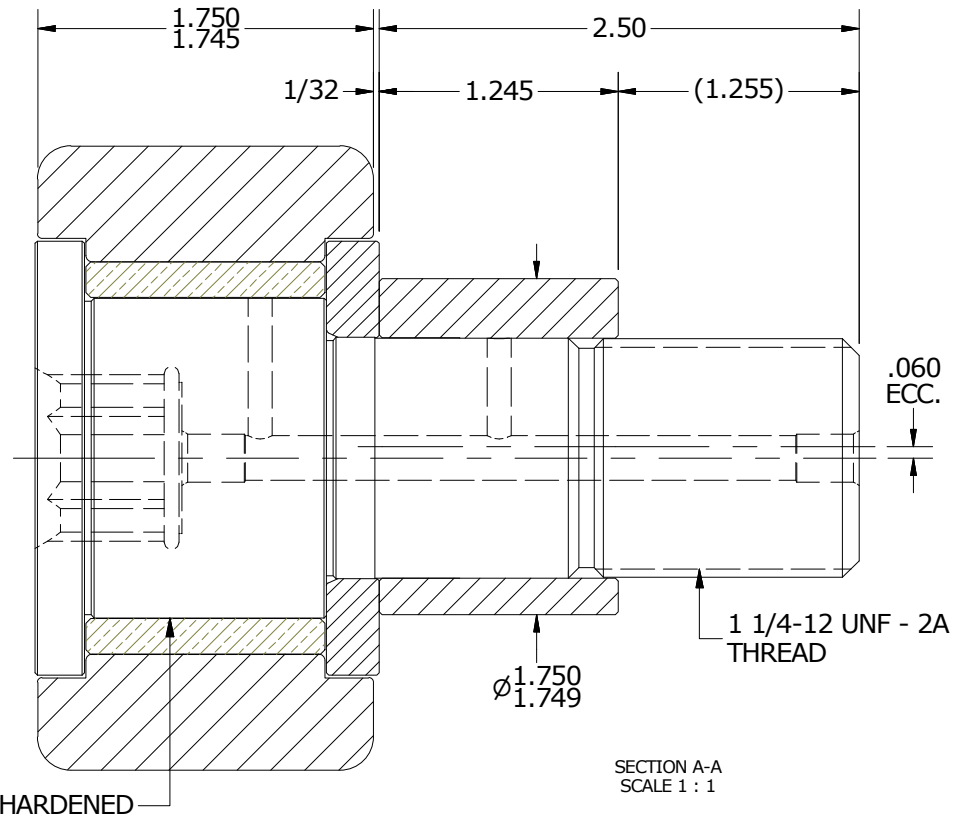
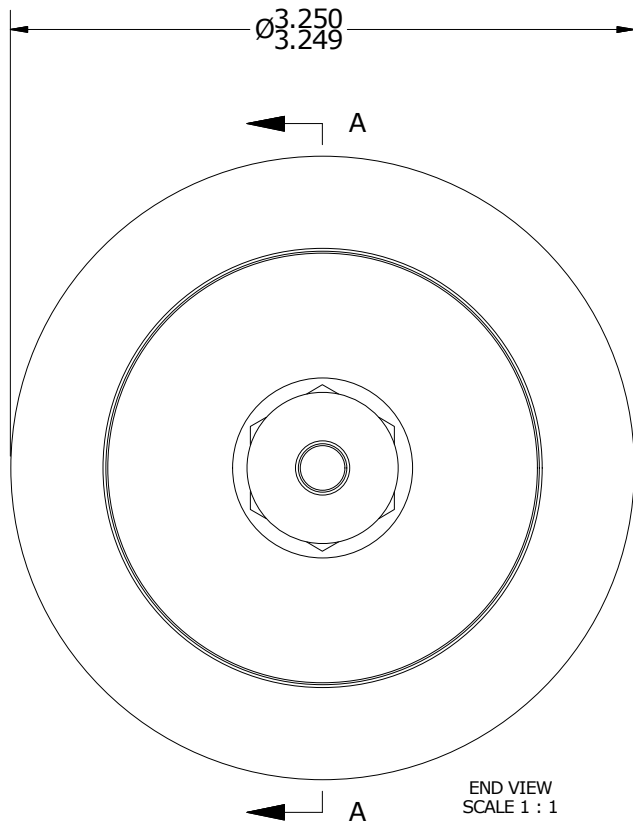
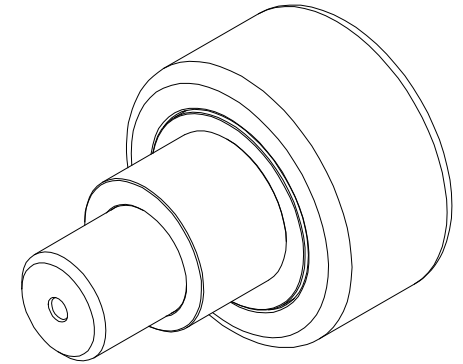

MATERIAL NOTES:

OUTER RING - BEARING STEEL, HEAT TREATED
 STUD - BEARING STEEL, ZONE HARDENED
 WASHER - COLD ROLLED STEEL, HEAT TREATED
 BUSHING - SINTERED BRONZE
 ECCENTRIC SLEEVE - COLD ROLLED STEEL

CUSTOMER PART#

XX = ± .01
 XXX = ± .005
 XXXX = ± .0005
 ANGLES = ± 1'
 INCH [METRIC]
 FRACTION = ± 1/32

CARTER MANUFACTURING IS NOT RESPONSIBLE FOR TYPOGRAPHICAL ERRORS

CARTER MANUFACTURING CO., INC.

GRAND HAVEN, MICHIGAN 49417

ENGINEERING CHANGE ORDER NOTE

REVISION

PART NAME: ASSEMBLY

A

AUTHOR BY
HG

DRAWN BY
SGW

CHK'D BY
MD

SALES
KR

MATERIAL
NOTED

REVISION BY
SGW

DATE
1/2/2017

DATE
12/13/2016

DATE
12/21/2016

DATE
12/13/2016

SHEET
1 OF 2