

NOTES:

1. BUSHING IS IMPREGNATED WITH OIL
2. ALL EXPOSED SURFACES HAVE BLACK OXIDE

MS NO.

NSN NO.

DRAWING NO.

SFH-44-A

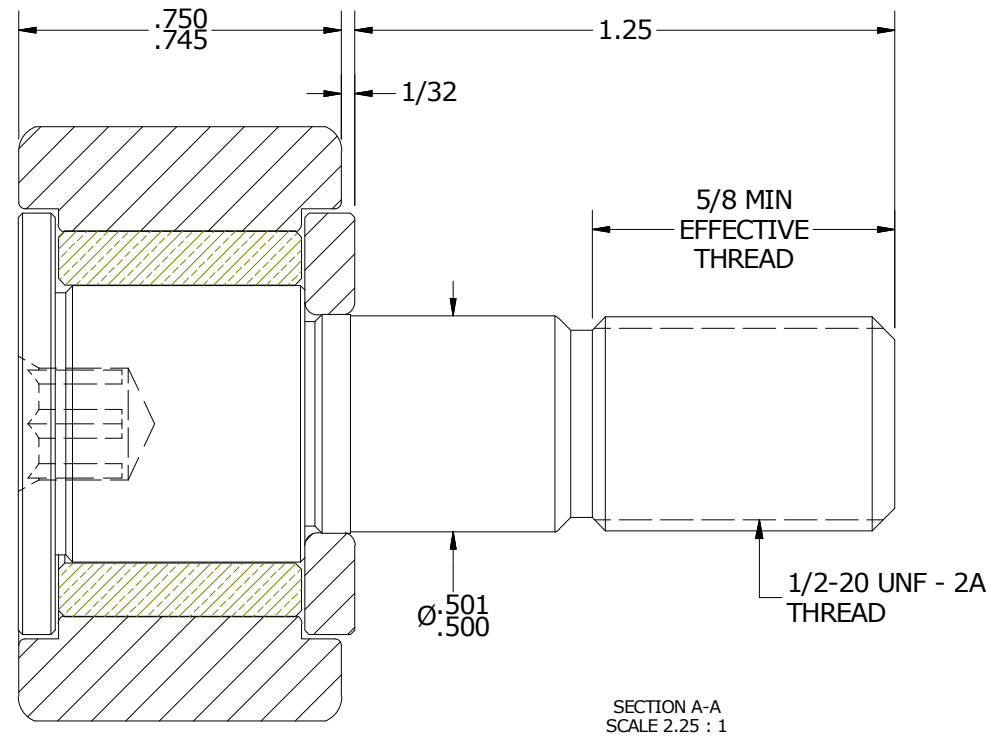
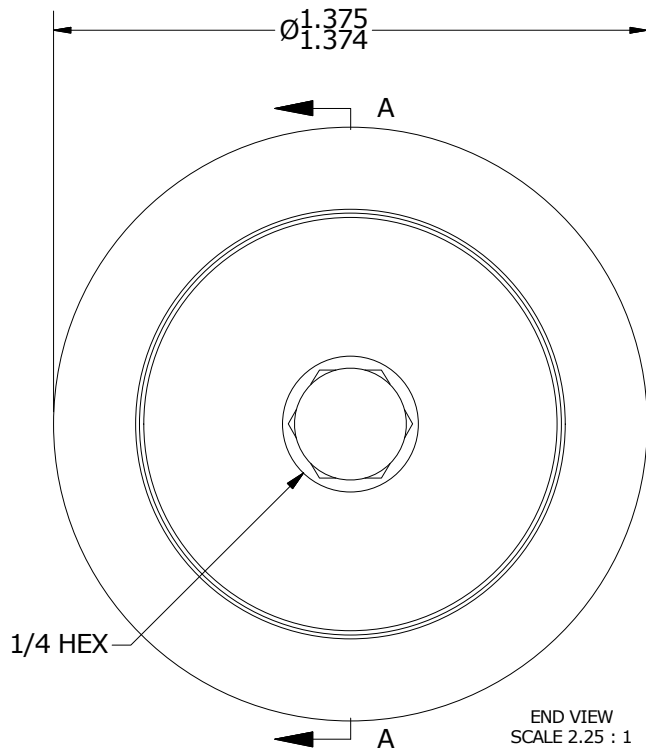
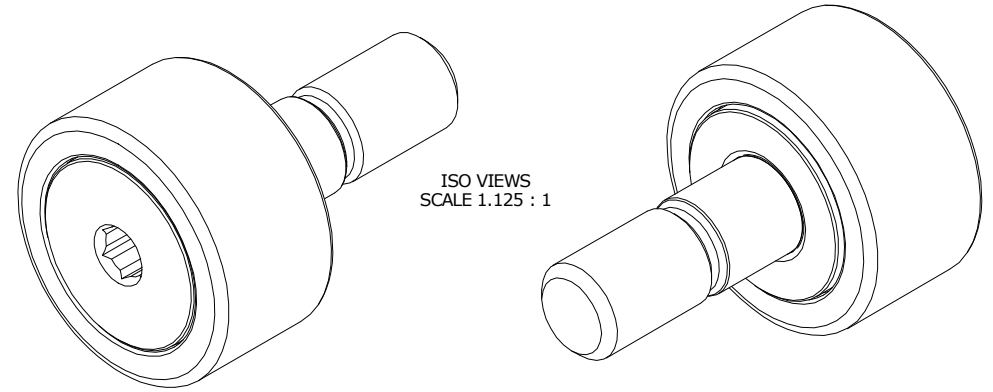

MATERIAL NOTES:

OUTER RING - BEARING STEEL, HEAT TREATED  
 STUD - COLD ROLLED STEEL  
 WASHER - BEARING STEEL, HEAT TREATED  
 BUSHING - SINTERED BRONZE

CUSTOMER PART#

XX = ± .01  
 XXX = ± .005  
 XXXX = ± .0005  
 ANGLES = ± 1'  
 INCH [METRIC]  
 FRACTION = ± 1/32

CARTER MANUFACTURING IS NOT RESPONSIBLE FOR TYPOGRAPHICAL ERRORS

**CARTER MANUFACTURING CO., INC.**

GRAND HAVEN, MICHIGAN 49417

REVISION

PART NAME: ASSEMBLY

ENGINEERING CHANGE ORDER NOTE

**B**

AUTHOR BY  
HG

DRAWN BY  
JAF

CHK'D BY  
MD

SALES  
KR

MATERIAL  
NOTED

REVISION BY  
SGW

DATE  
2/15/2017

DATE  
8/15/2006

DATE  
2/15/2017

DATE  
2/15/2017

SHEET  
1 OF 2