

NOTES:

1. BEARING IS PACKED WITH NLGI GRADE 2, NEVERLUBE GREASE (UNLESS OTHERWISE SPECIFIED)
2. ALL EXPOSED SURFACES HAVE BLACK OXIDE

MS NO.

NSN NO.

DRAWING NO.

SFH-36-A

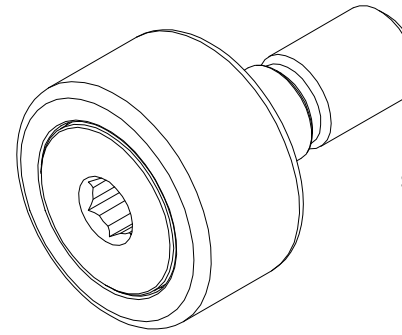

ISO VIEWS
SCALE 1.25 : 1

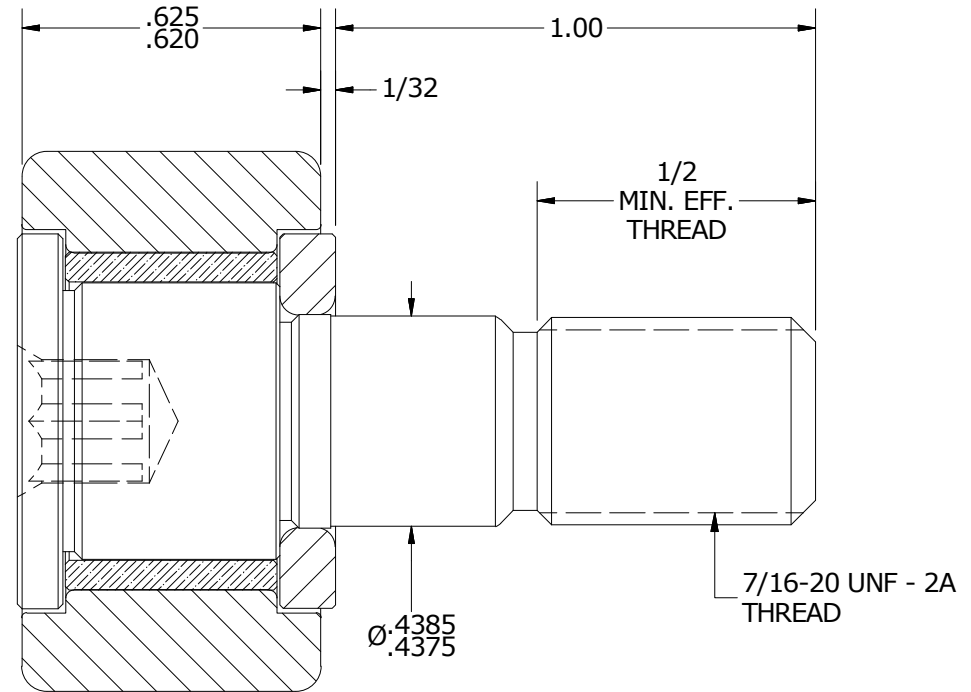
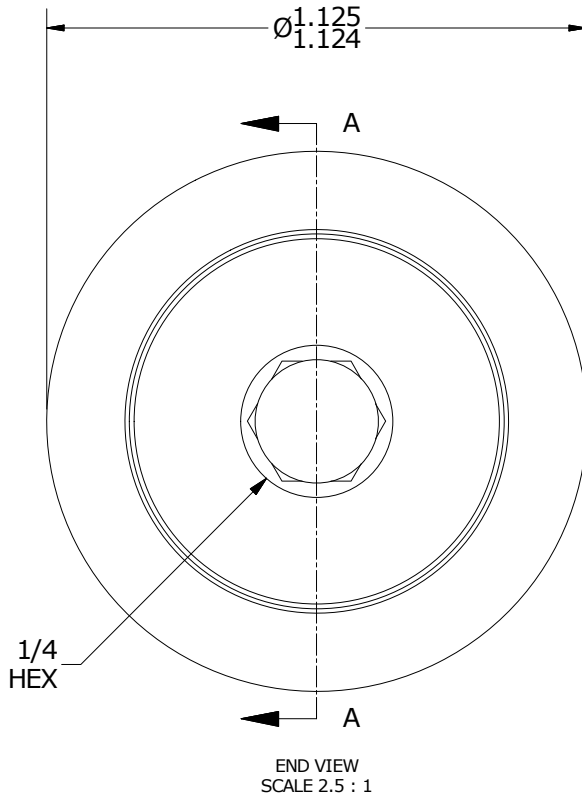
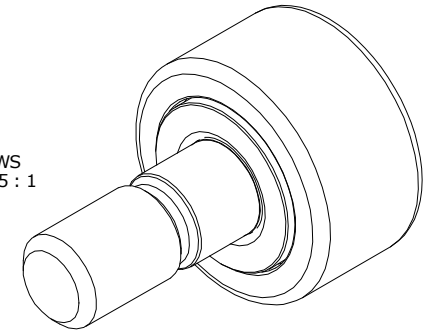

MATERIAL NOTES:

- OUTER RACE - BEARING STEEL, HEAT TREATED
- STUD - COLD ROLLED STEEL
- WASHER - BEARING STEEL, HEAT TREATED
- BUSHING - SINTERED BRONZE SAE 841

CUSTOMER PART#

XX = ± .01
XXX = ± .005
XXXX = ± .0005
ANGLES = ± 1'
INCH [METRIC]
FRACTION = ± 1/32

CARTER MANUFACTURING IS NOT RESPONSIBLE FOR TYPOGRAPHICAL ERRORS

CARTER MANUFACTURING CO., INC.

GRAND HAVEN, MICHIGAN 49417

ENGINEERING CHANGE ORDER NOTE

REVISION

PART NAME: ASSEMBLY

D

AUTHOR BY
HG

DRAWN BY
GJP

CHK'D BY
SGW

SALES
KR

MATERIAL
NOTED

REVISION BY

DATE

DATE

DATE

DATE

SHEET

MD

9/9/2016

3/12/1999

9/9/2016

9/9/2016

1 OF 2