

NOTES:

1. BUSHING IS IMPREGNATED WITH OIL.
2. ALL EXPOSED SURFACES HAVE BLACK OXIDE.

MS NO.

NSN NO.

DRAWING NO.

SFH-24-A

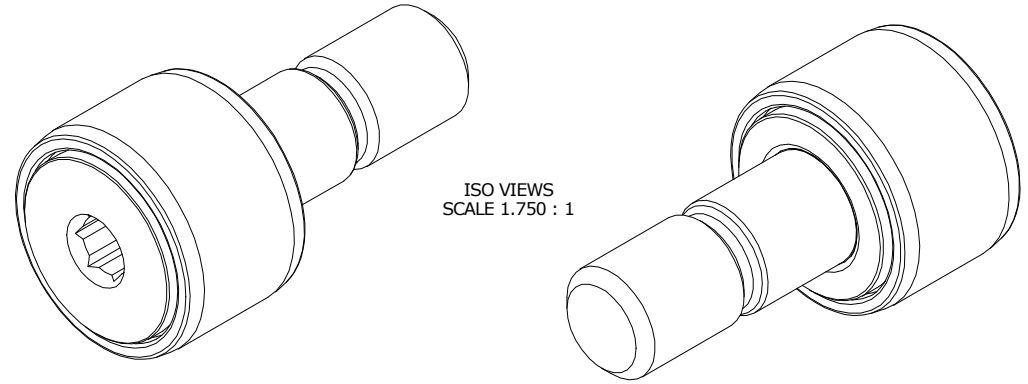

ISO VIEWS  
SCALE 1.750 : 1

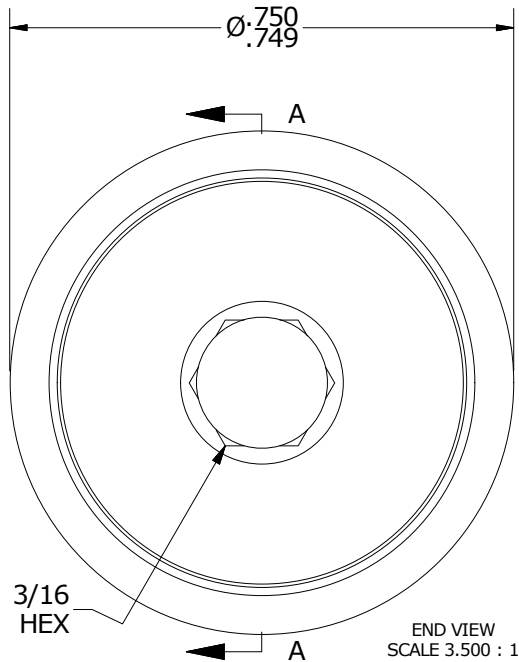

END VIEW  
SCALE 3.500 : 1

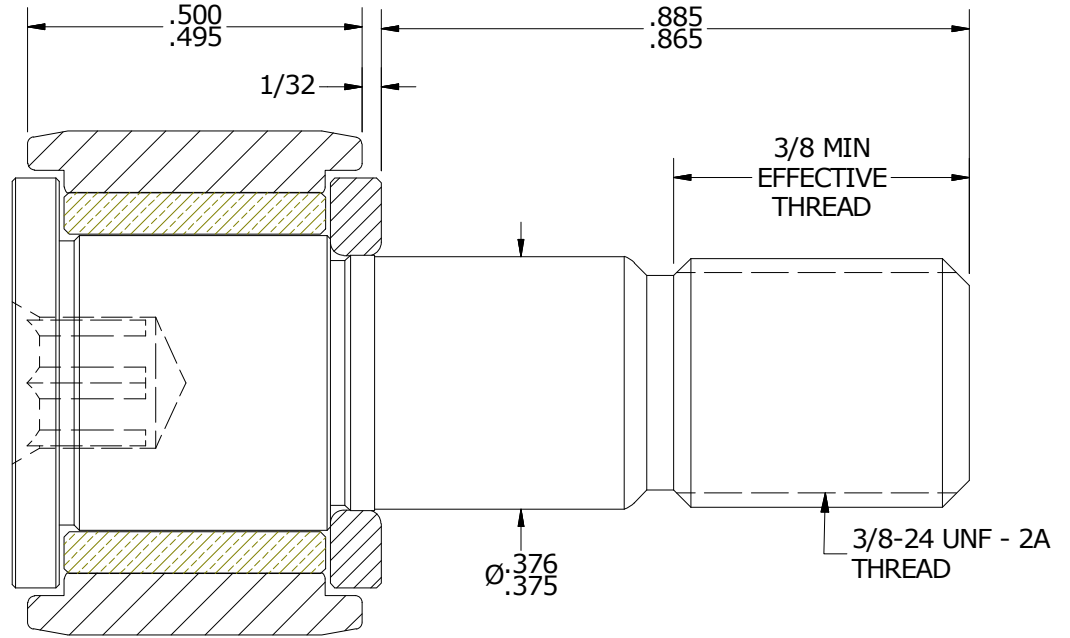

SECTION A-A  
SCALE 3.500 : 1

MATERIAL NOTES:

- OUTER RING - BEARING STEEL, HEAT TREATED
- STUD - COLD ROLLED STEEL
- WASHER - BEARING STEEL, HEAT TREATED
- BUSHING - SINTERED BRONZE

CUSTOMER PART#

XX = ± .01  
XXX = ± .005  
XXXX = ± .0005  
ANGLES = ± 1'  
INCH [METRIC]  
FRACTION = ± 1/32

CARTER MANUFACTURING IS  
NOT RESPONSIBLE FOR  
TYPOGRAPHICAL ERRORS

**CARTER MANUFACTURING CO., INC.**

GRAND HAVEN, MICHIGAN 49417

ENGINEERING CHANGE ORDER NOTE

REVISION

PART NAME: ASSEMBLY

C

AUTHOR BY  
HG

DRAWN BY  
GJP

CHK'D BY  
MD

SALES  
KR

MATERIAL  
NOTED

REVISION BY  
SGW

DATE  
5/5/2017

DATE  
9/7/2000

DATE  
5/4/2017

DATE  
5/5/2017

SHEET  
1 OF 2