

NOTES:

1. BUSHING IS IMPREGANTED WITH OIL
2. ALL EXPOSED STEEL SURFACES HAVE BLACK OXIDE

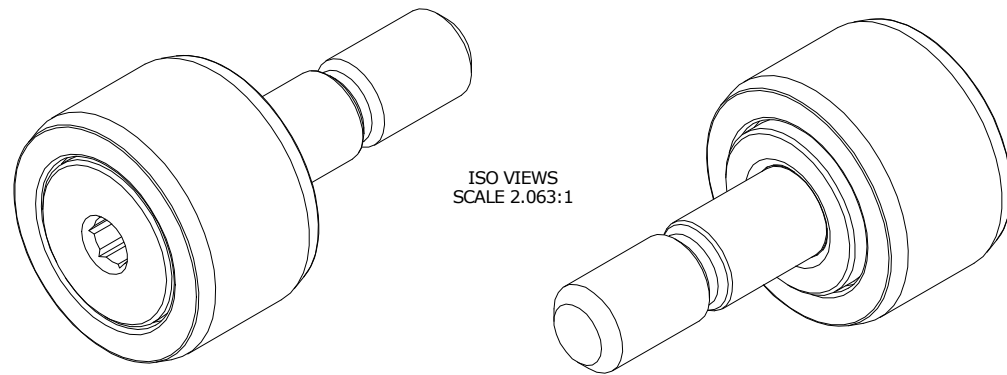

ISO VIEWS
SCALE 2.063:1

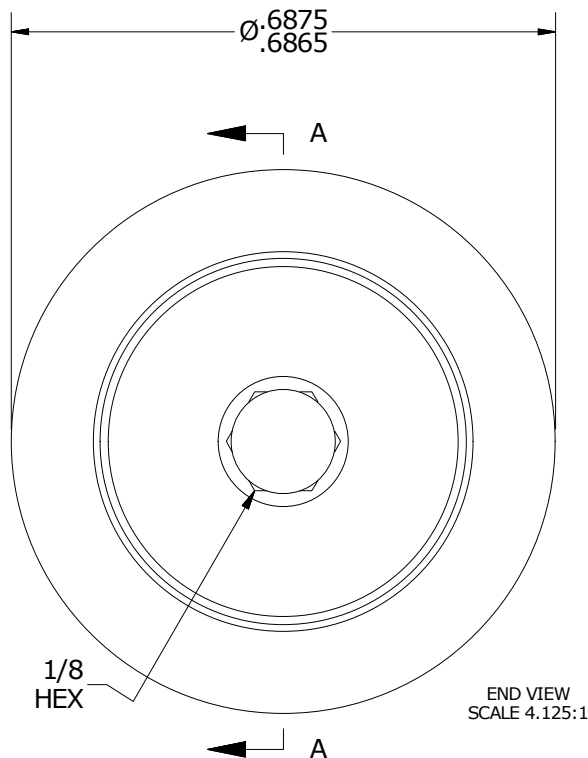

END VIEW
SCALE 4.125:1

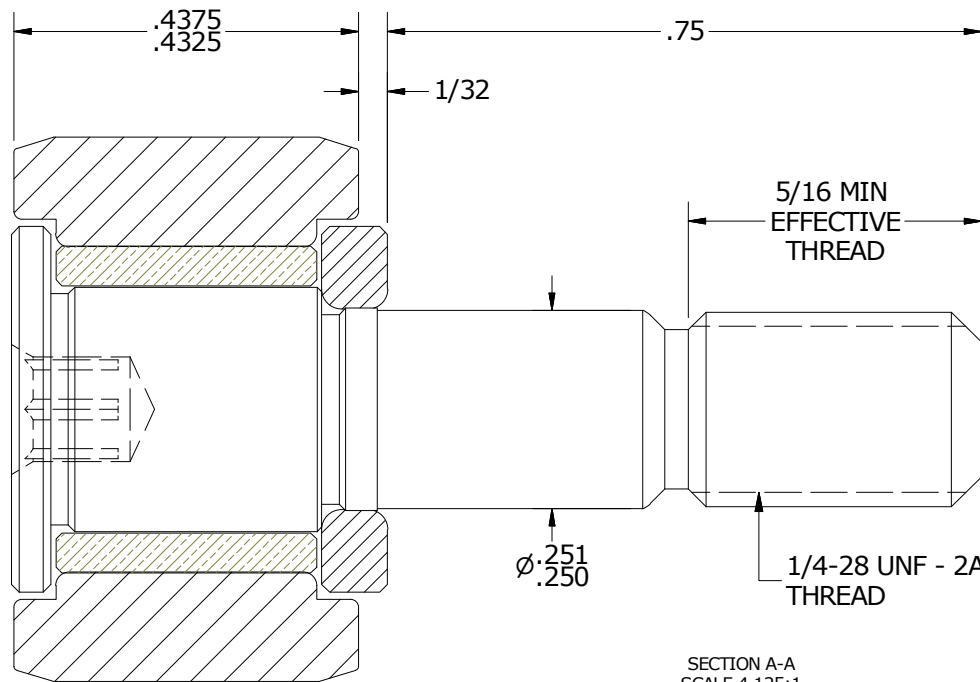

SECTION A-A
SCALE 4.125:1

MATERIAL NOTES:

- OUTER RING - BEARING STEEL, HEAT TREATED
- STUD - COLD ROLLED STEEL
- BUSHING - SINTERED BRONZE
- WASHER - BEARING STEEL, HEAT TREATED**

** (DEPENDING ON MATERAIL AVAILABILITY, MAY BE CONSTRUCTED FROM COLD ROLLED STEEL)

CUSTOMER PART#
XX = ± .01
XXX = ± .005
XXXX = ± .0005
ANGLES = ± 1'
INCH [METRIC]
FRACTION = ± 1/32

CARTER MANUFACTURING IS NOT RESPONSIBLE FOR TYPOGRAPHICAL ERRORS

CARTER MANUFACTURING CO., INC.
GRAND HAVEN, MICHIGAN 49417

ENGINEERING CHANGE ORDER NOTE

REVISION		PART NAME: ASSEMBLY					
C	AUTHOR BY HG	DRAWN BY JAF	CHK'D BY MD	SALES KR	MATERIAL NOTED		
REVISION BY SGW	DATE 11/1/2016	DATE 8/15/2006	DATE 10/31/2016	DATE 11/4/2016	SHEET 1 OF 2		