

LOAD RATINGS	
RATING	Lbs
RADIAL BASIC DYNAMIC	3,872
MAXIMUM STATIC CAPACITY	7,896

NOTES:
 1. BEARING IS PACKED WITH NLGI GRADE 2, FOOD GRADE H1 GREASE (UNLESS OTHERWISE SPECIFIED)

MS NO.	NSN NO.	DRAWING NO.	SCH-52-SB
--------	---------	-------------	-----------

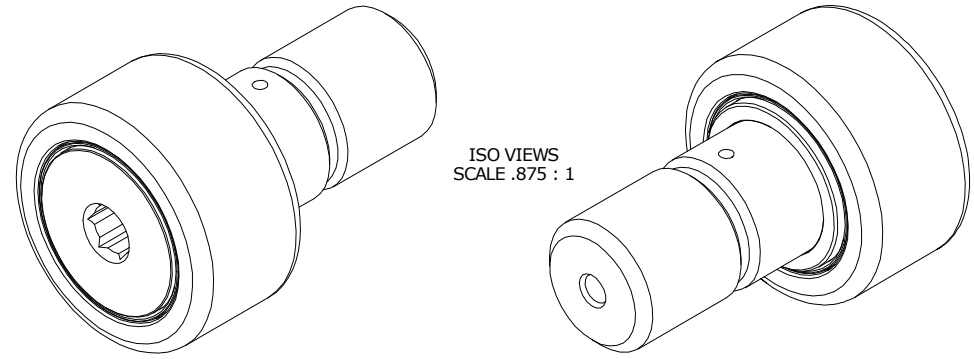

ISO VIEWS
SCALE .875 : 1

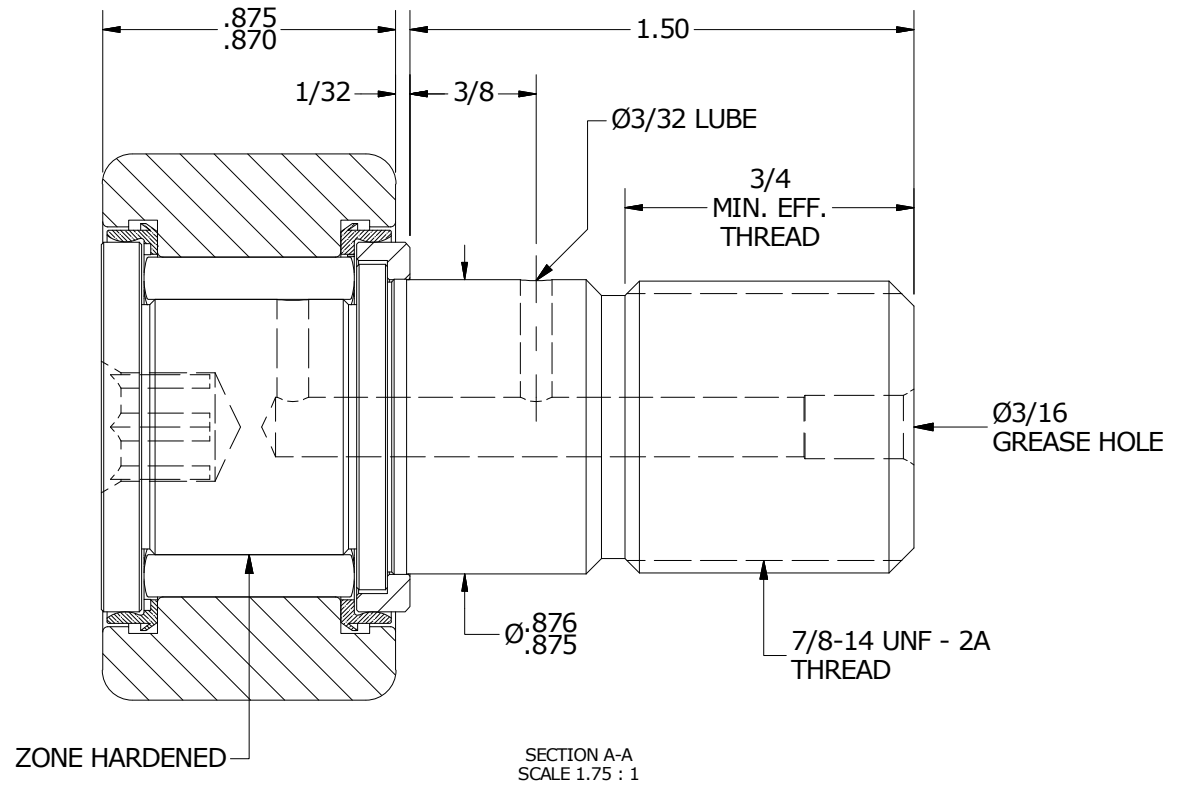
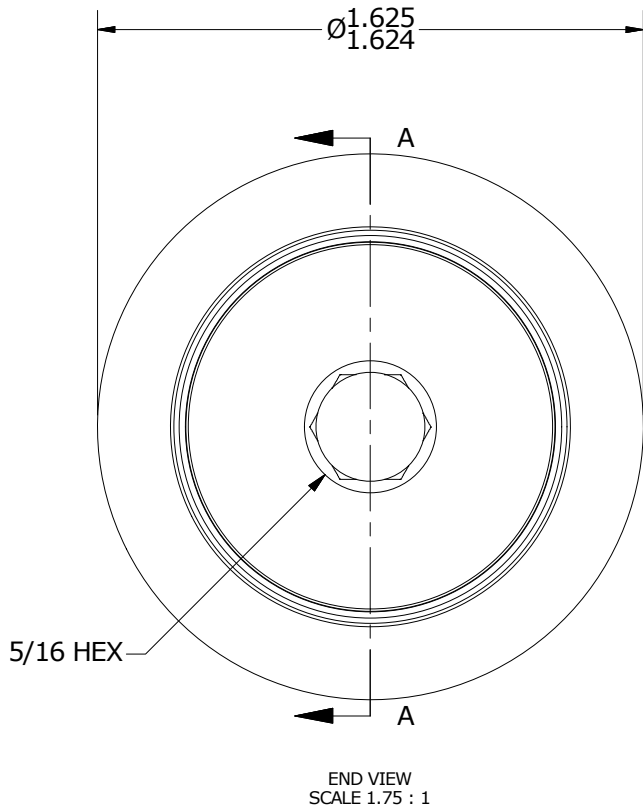

MATERIAL NOTES:

OUTER RING - 440C STAINLESS STEEL, HEAT TREATED
 STUD - 440C STAINLESS STEEL, ZONE HARDENED
 NEEDLE ROLLERS - 440C STAINLESS STEEL, HEAT TREATED
 WASHER - 440C STAINLESS STEEL, HEAT TREATED
 SEALS - SYNTHETIC

CUSTOMER PART#

XX = ± .01
 XXX = ± .005
 XXXX = ± .0005
 ANGLES = ± 1'
 INCH [METRIC]
 FRACTION = ± 1/32

CARTER MANUFACTURING IS NOT RESPONSIBLE FOR TYPOGRAPHICAL ERRORS

CARTER MANUFACTURING CO., INC.
 GRAND HAVEN, MICHIGAN 49417

ENGINEERING CHANGE ORDER NOTE

REVISION

PART NAME: Assembly

PRODUCT TYPE:

B

AUTHOR BY
HG

DRAWN BY
JAF

CHK'D BY
SGW

SALES
KPR

MATERIAL
NOTED

REVISION BY
MD

DATE
7/27/2018

DATE
7/26/2006

DATE
7/27/2018

DATE
7/25/2006

SHEET
1 OF 2