

LOAD RATINGS		
RATING	lbf	Newtons
RADIAL BASIC DYNAMIC	6,472	28,789
MAXIMUM STATIC CAPACITY	8,456	37,614

MS NO.	NSN NO.	DRAWING NO.
--------	---------	-------------

RECOMMENDED MOUNTING HOLE Ø		
Limit	Inch	mm
MIN	1.189	30.2006
MAX	1.191	30.2514

- NOTES:
- BEARING IS PACKED WITH NLGI GRADE 2, FOOD GRADE H1 GREASE (UNLESS OTHERWISE SPECIFIED)
 - LIMITING SPEED:
A. GREASE = 1,400

MAXIMUM CLAMPING TORQUE		
Thread Type	Inch Lbs	Nm
DRY	1,500	169.5
LUBRICATED	750	84.7

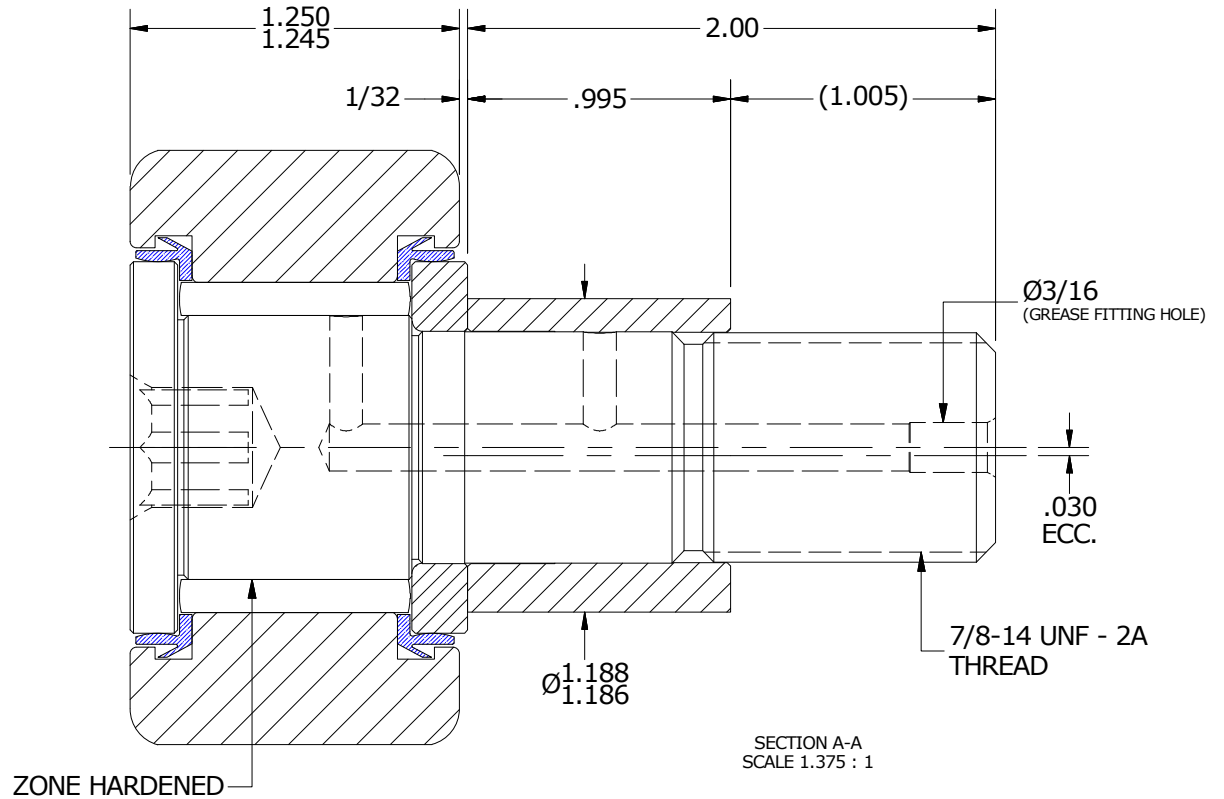
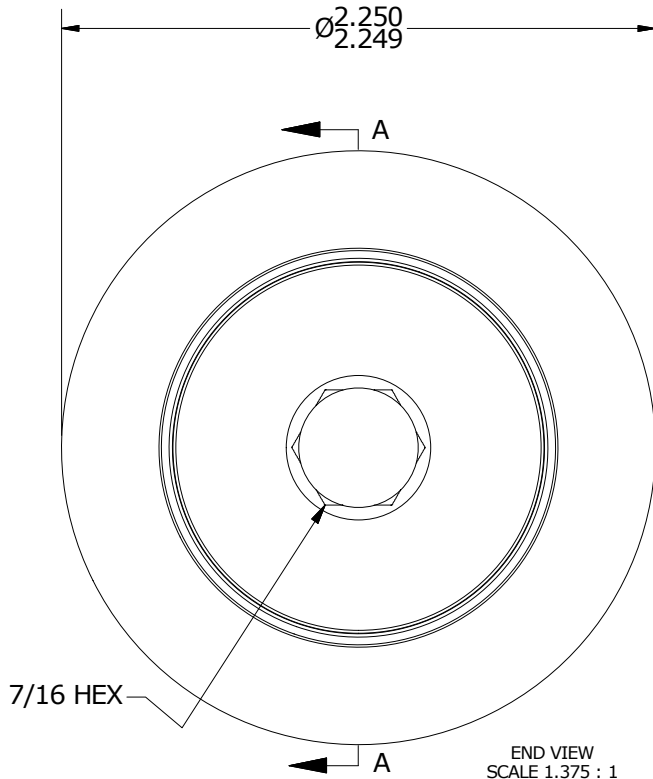
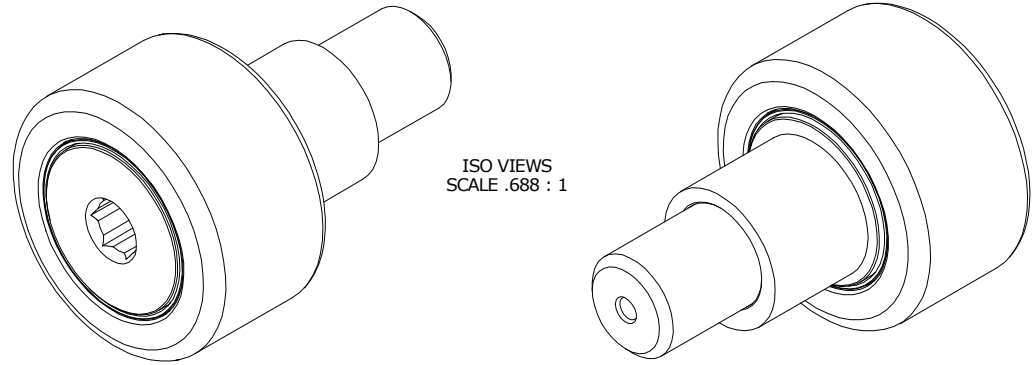

MATERIAL NOTES:

OUTER RING - 440C STAINLESS, HEAT TREATED
 STUD - 440C STAINLESS, ZONE HARDENED
 NEEDLE ROLLER(S) - 440C STAINLESS, HEAT TREATED
 WASHER - 440C STAINLESS, HEAT TREATED
 ECCENTRIC SLEEVE - 300 SERIES STAINLESS STEEL
 SEAL(S) - SYNTHETIC

CUSTOMER PART#
 XX = ± .01
 XXX = ± .005
 XXXX = ± .0005
 ANGLES = ± 1'
 INCH [METRIC]
 FRACTION = ± 1/32

CARTER MANUFACTURING IS NOT RESPONSIBLE FOR TYPOGRAPHICAL ERRORS

CARTER MANUFACTURING CO., INC.
 GRAND HAVEN, MICHIGAN 49417

ENGINEERING CHANGE ORDER NOTE

REVISION		PART NAME: ASSEMBLY			PRODUCT TYPE: CNB / SC	
B	AUTHOR BY HG	DRAWN BY AJH	CHK'D BY MD	SALES KR	MATERIAL NOTED	
REVISION BY SGW	DATE 7/26/2018	DATE 11/19/2001	DATE 7/25/2018	DATE 7/25/2018	SHEET 1 OF 2	