

LOAD RATINGS		
RATING	Lbs	Newtons
RADIAL BASIC DYNAMIC	1,490	6,628
MAXIMUM STATIC CAPACITY	1,500	6,672

NOTES:

1. BEARING IS PACKED WITH NLGI GRADE 2, H1, FOOD GREASE (UNLESS OTHERWISE SPECIFIED)
2. CUSTOM LASER ETCHING IS AVAILABLE UPON REQUEST
3. LIMITING SPEED:
  - A. GREASE = 6,400 RPM

RECOMMENDED MOUNTING HOLE Ø		
Limit	Inch	mm
MIN	.502	12.5708
MAX	.504	12.8016

MAXIMUM CLAMPING TORQUE**		
Thread Type	Inch Lbs	Nm
LUBRICATED	47.5	5.5

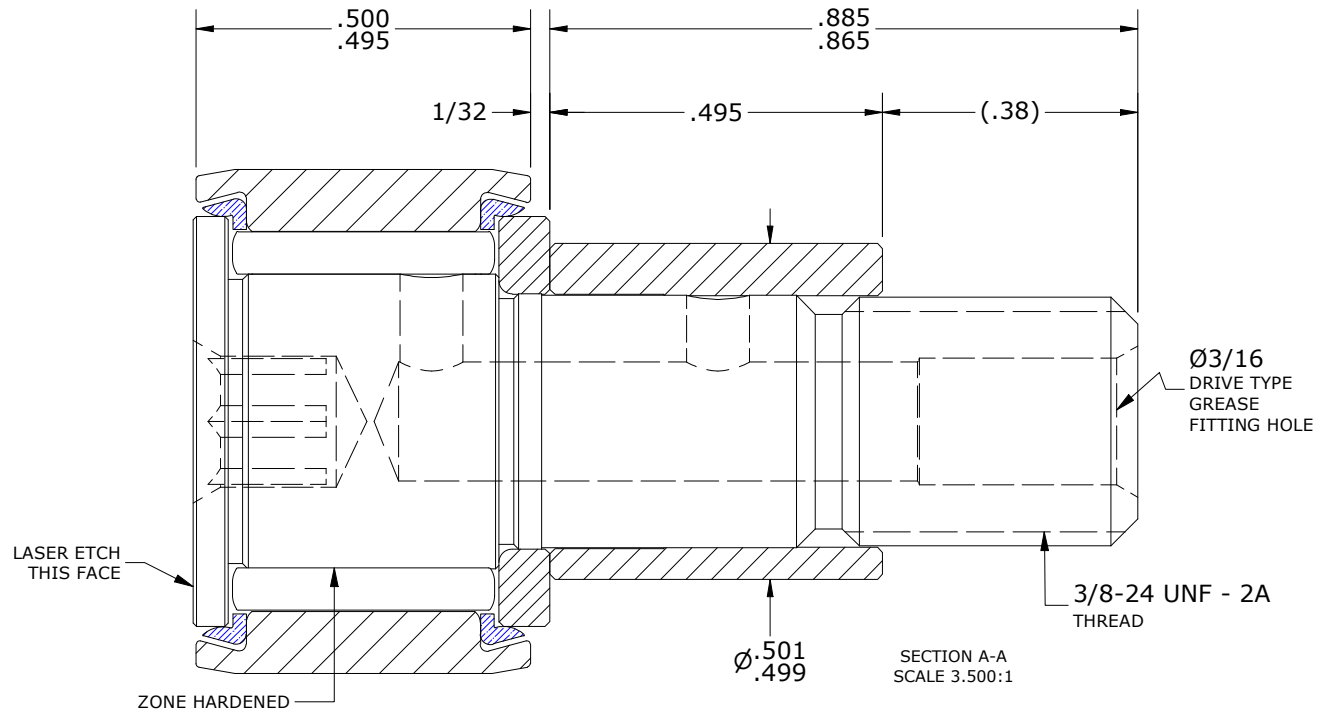
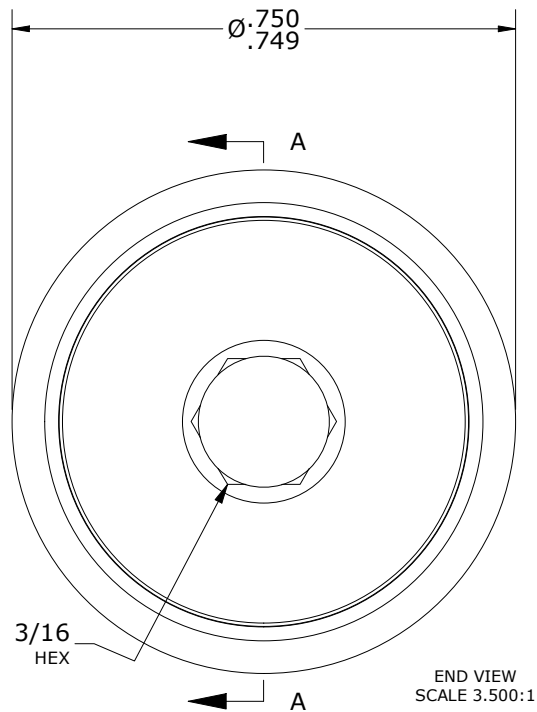
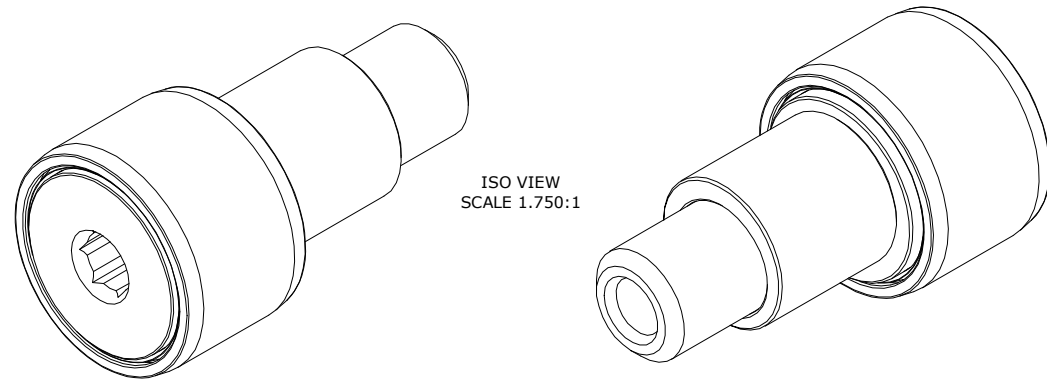

\*\*TORQUE SPECIFICATION IS BASED ON LUBRICATED THREADS, IF USING DRY THREADS DOUBLE TORQUE VALUE

MATERIAL NOTES:

OUTER RING - 440C STAINLESS STEEL, HEAT TREATED  
 STUD - 440C STAINLESS STEEL, ZONE HARDENED  
 NEEDLE ROLLER(S) - 440C STAINLESS STEEL, HEAT TREATED  
 WASHER - 440C STAINLESS STEEL, HEAT TREATED  
 SEAL(S) - SYNTHETIC

CUSTOMER PART#

XX = ± .01  
 XXX = ± .005  
 XXXX = ± .0005  
 ANGLES = ± 1'  
 INCH [METRIC]  
 FRACTION = ± 1/32

CARTER MANUFACTURING IS NOT RESPONSIBLE FOR TYPOGRAPHICAL ERRORS

**CARTER MANUFACTURING CO., INC.**  
 GRAND HAVEN, MICHIGAN 49417

ENGINEERING CHANGE ORDER NOTE

REVISION

PART NAME: ASSEMBLY

PRODUCT TYPE: SCE

D

AUTHOR BY  
HG

DRAWN BY  
ED

CHK'D BY  
MD

SALES  
KR

MATERIAL  
NOTED

REVISION BY  
SGW

DATE  
6/23/2020

DATE  
7/25/2006

DATE  
6/22/2020

DATE  
5/5/2017

SHEET  
1 OF 2