

| LOAD RATINGS | |
|-------------------------|-------|
| RATING | Lbs |
| RADIAL BASIC DYNAMIC | 6,472 |
| MAXIMUM STATIC CAPACITY | 8,456 |

NOTES:
 1. BEARING IS PACKED WITH NLGI GRADE 2, FOOD GRADE H1 GREASE (UNLESS OTHERWISE SPECIFIED)

| | | | |
|--------|---------|-------------|----------|
| MS NO. | NSN NO. | DRAWING NO. | SC-64-SB |
|--------|---------|-------------|----------|

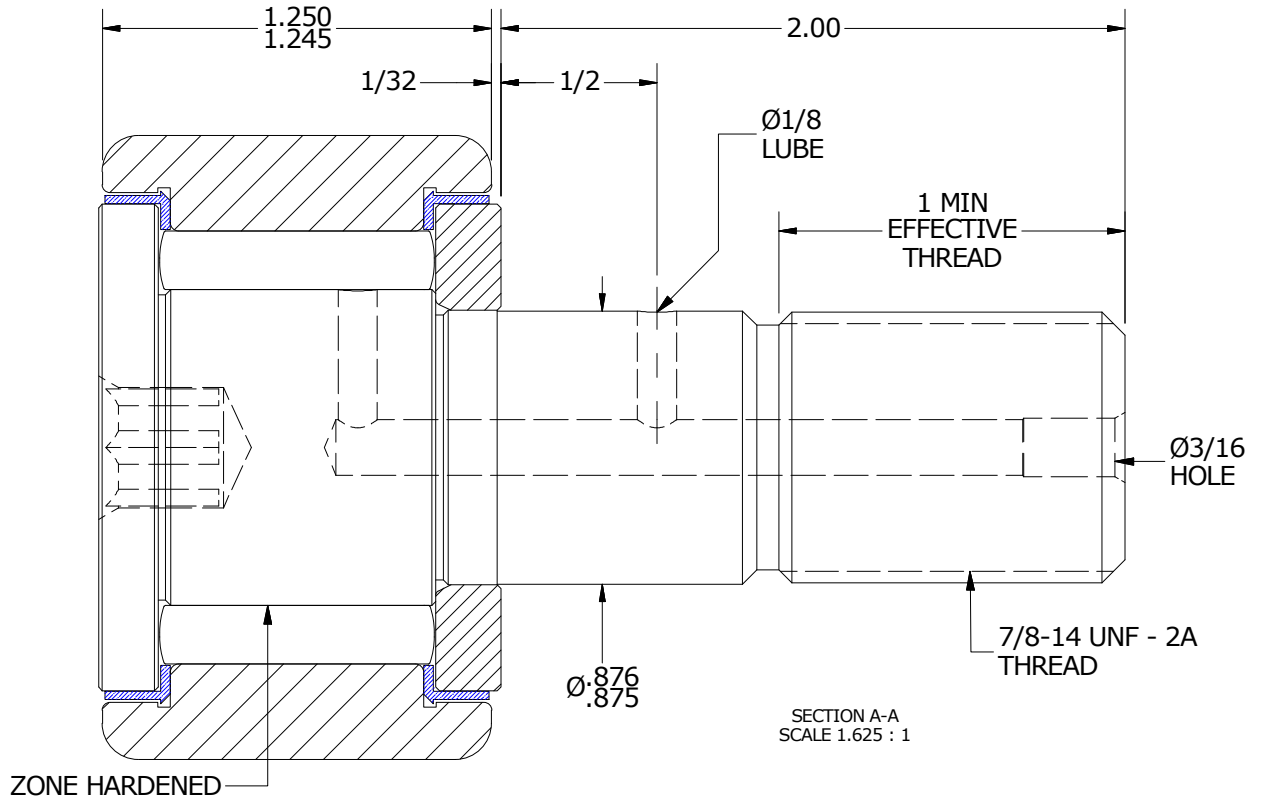
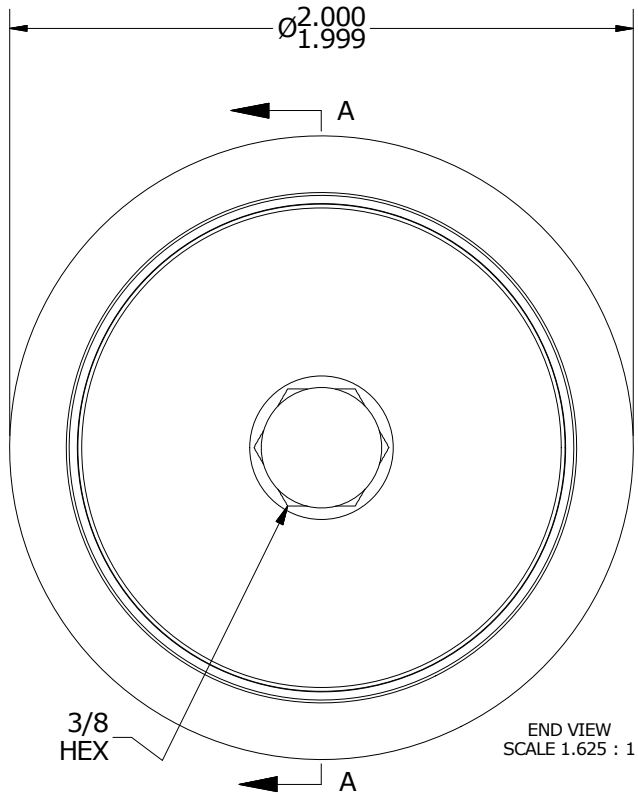
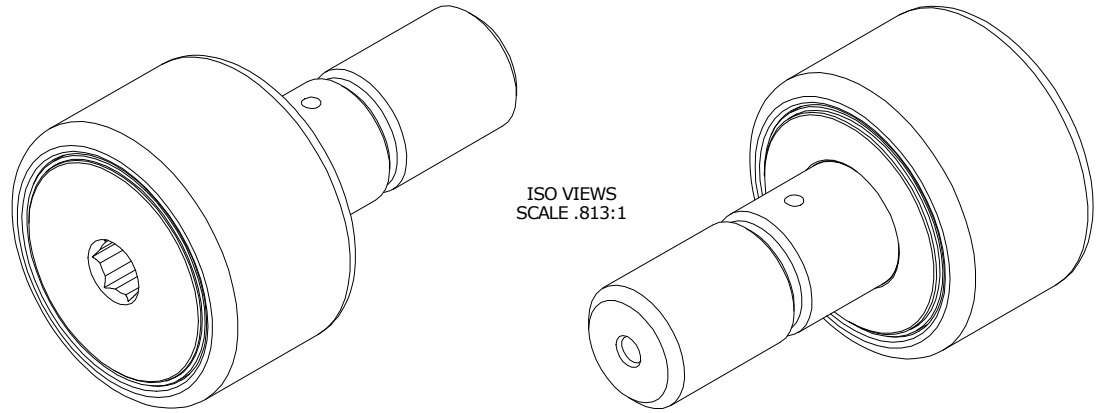

MATERIAL NOTES:

OUTER RING - 440C STAINLESS, HEAT TREATED
 STUD - 440C STAINLESS, ZONE HARDENED
 NEEDLE ROLLER(S) - 440C STAINLESS, HEAT TREATED
 WASHER - 440C STAINLESS, HEAT TREATED
 SEAL(S) - SYNTHETIC

CUSTOMER PART#
 XX = ± .01
 XXX = ± .005
 XXXX = ± .0005
 ANGLES = ± 1'
 INCH [METRIC]
 FRACTION = ± 1/32

CARTER MANUFACTURING IS NOT RESPONSIBLE FOR TYPOGRAPHICAL ERRORS

CARTER MANUFACTURING CO., INC.
 GRAND HAVEN, MICHIGAN 49417

ENGINEERING CHANGE ORDER NOTE

| REVISION | | PART NAME: ASSEMBLY | | | |
|--------------------|-------------------|---------------------|-------------------|--------------------|-------------------|
| A | AUTHOR BY DB | DRAWN BY GJP | CHK'D BY MD | SALES KPR | MATERIAL NOTED |
| REVISION BY GJP | DATE 2/14/2008 | DATE 10/30/2000 | DATE 2/14/2008 | DATE 10/28/2000 | SHEET 1 OF 2 |