

LOAD RATINGS	
RATING	Lbs
RADIAL BASIC DYNAMIC	1,800
MAXIMUM STATIC CAPACITY	2,040

NOTES:
 1. BEARING COMES PACKED WITH CARTER STANDARD H1 FOOD GRADE GREASE

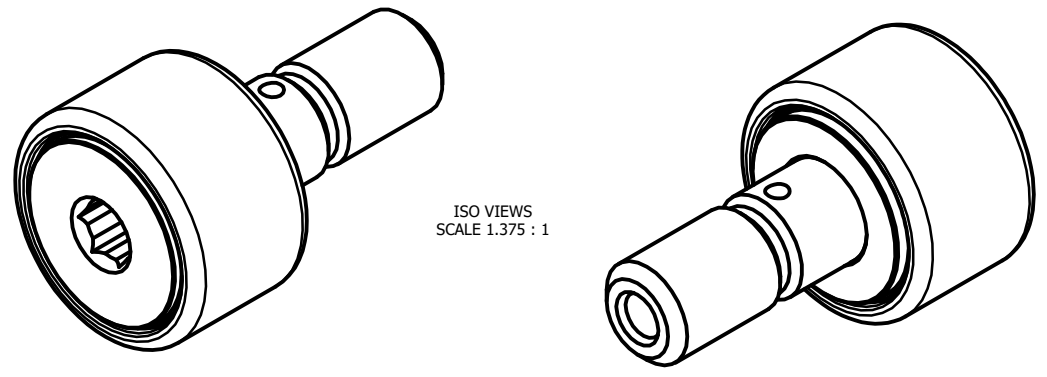

ISO VIEWS
 SCALE 1.375 : 1

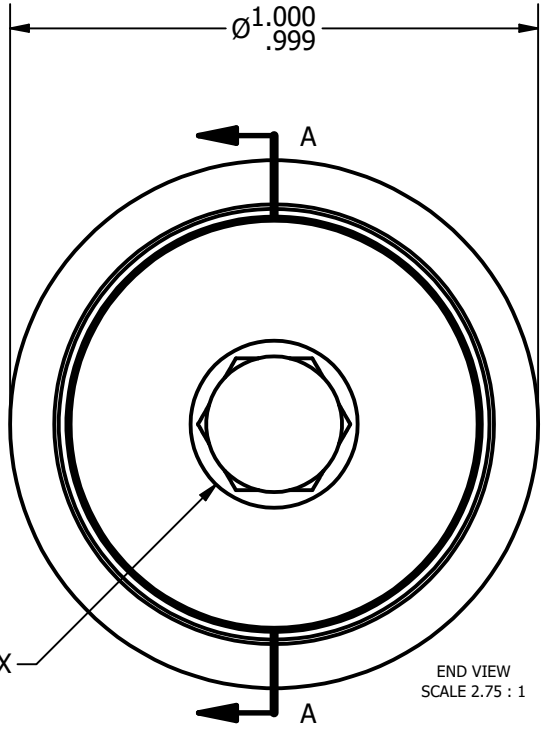

END VIEW
 SCALE 2.75 : 1

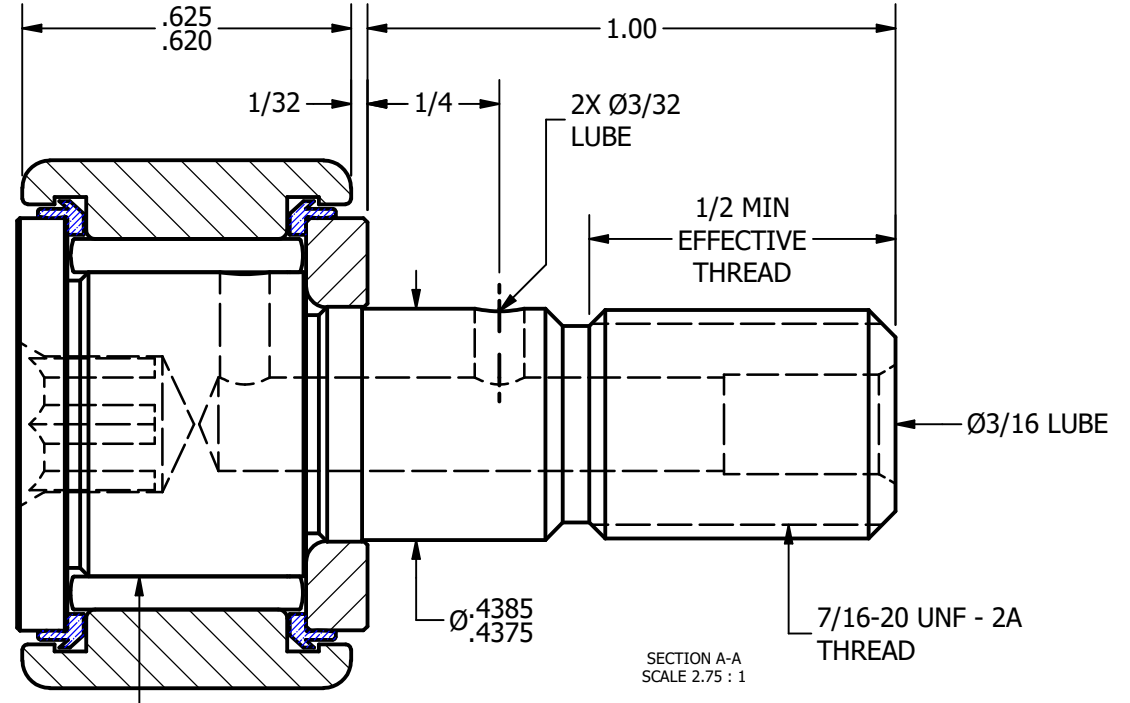

SECTION A-A
 SCALE 2.75 : 1

MATERIAL NOTES:
 OUTER RACE - 440C STAINLESS STEEL, HEAT TREATED
 STUD - 440C STAINLESS STEEL, ZONE HARDENED
 WASHER - 440C STAINLESS STEEL, HEAT TREATED
 NEEDLE ROLLER - 440C STAINLESS STEEL, HEAT TREATED
 SEAL - SYNTHETIC

CUSTOMER PART#	.XX = ± .01 .XXX = ± .005 .XXXX = ± .0005 ANGLES = ± 1' INCH [METRIC] FRACTION = ± 1/32
CHANGE NOTE:	

CARTER MANUFACTURING IS NOT RESPONSIBLE FOR TYPOGRAPHICAL ERRORS	
REVISION	
C	AUTHOR. BY DB
REV. BY	DATE
SGW	7/8/2013

CARTER MANUFACTURING CO., INC.					
GRAND HAVEN, MICHIGAN 49417					
PART NAME: ASSEMBLY			SHEET 1 OF 2		
	AUTHOR. BY	DRAWN BY	CHK'D BY	SALES	MATERIAL
	DB	GJP	MD	KR	NOTED
	DATE	DATE	DATE	DATE	DRAWING NO.
	7/8/2013	8/24/2000	7/8/2013	7/11/2013	SC-32-SB