

LOAD RATINGS		
RATING	Lbs	Newtons
RADIAL BASIC DYNAMIC	1,490	6,628
MAXIMUM STATIC CAPACITY	1,500	6,672

RECOMMENDED MOUNTING HOLE Ø		
Limit	Inch	mm
MIN	.3750	9.5250
MAX	.3755	9.5377

MAXIMUM CLAMPING TORQUE**		
Thread Type	Inch Lbs	Nm
LUBRICATED	47.5	5.5

NOTES:

1. BEARING IS PACKED WITH NLGI GRADE 2, H1, FOOD GREASE (UNLESS OTHERWISE SPECIFIED)
2. CUSTOM LASER ETCHING IS AVAILABLE UPON REQUEST
3. LIMITING SPEED:
A. GREASE = 5,400 RPM

MS NO.	NSN NO.	DRAWING NO.	SC-28-SB
--------	---------	-------------	----------

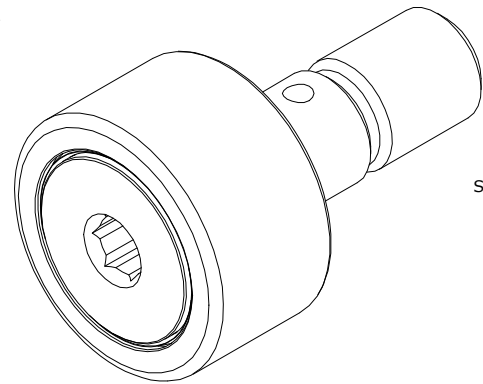

ISO VIEW
SCALE 1.750:1

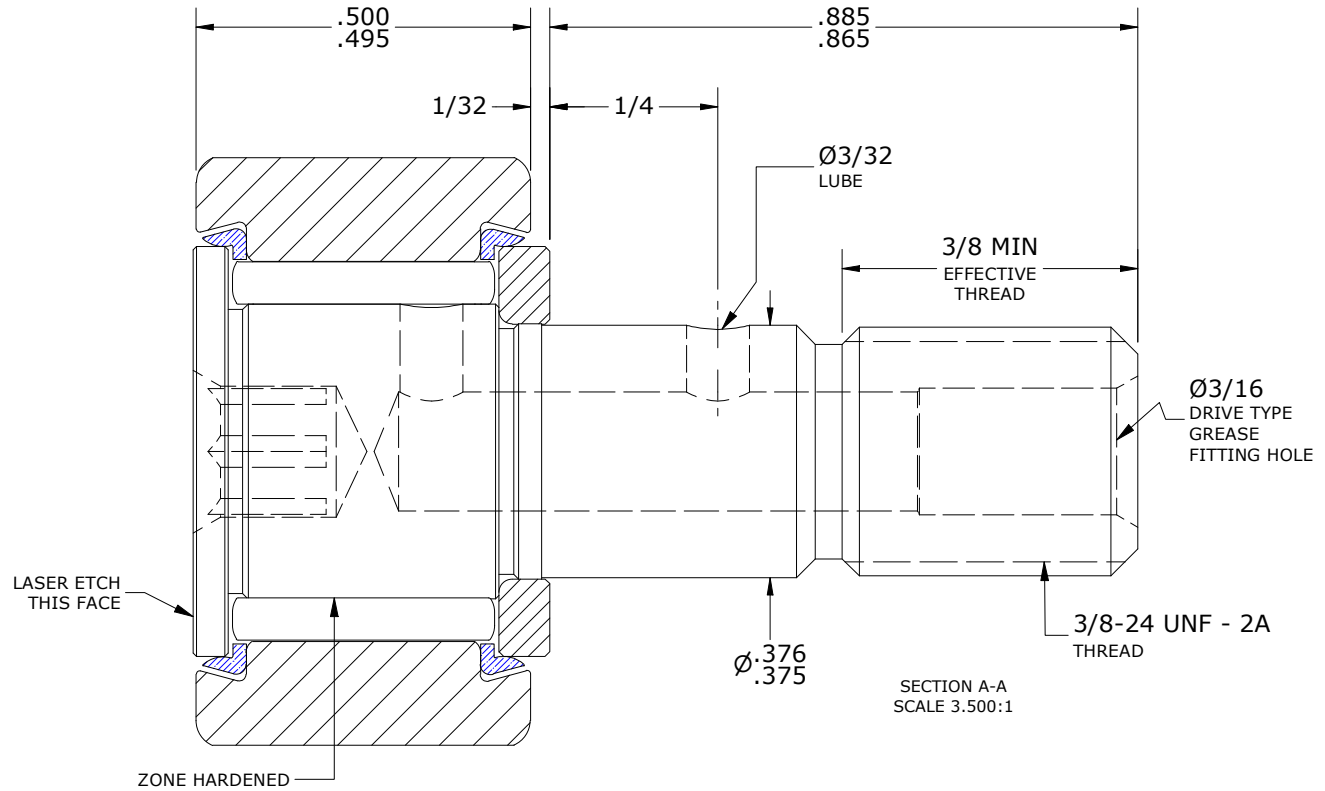
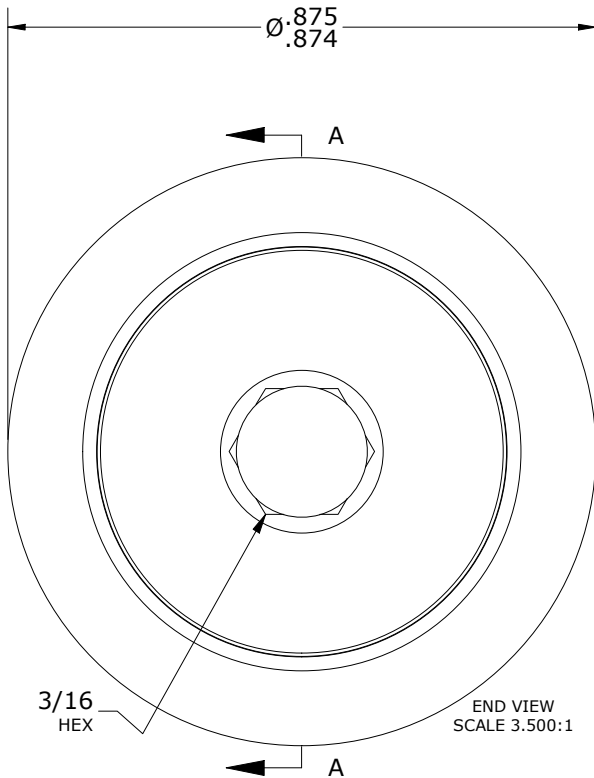
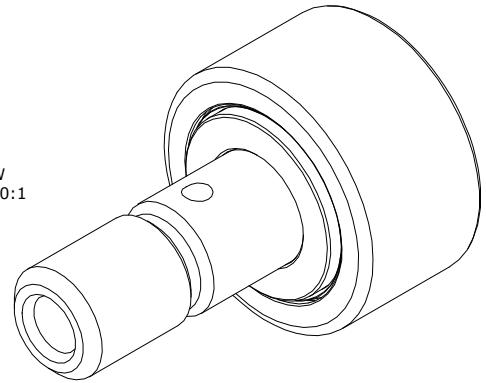

**TORQUE SPECIFICATION IS BASED ON LUBRICATED THREADS, IF USING DRY THREADS DOUBLE TORQUE VALUE

MATERIAL NOTES:

OUTER RING - 440C STAINLESS STEEL, HEAT TREATED
 STUD - 440C STAINLESS STEEL, ZONE HARDENED
 NEEDLE ROLLER(S) - 440C STAINLESS STEEL, HEAT TREATED
 WASHER - 440C STAINLESS STEEL, HEAT TREATED
 SEAL(S) - SYNTHETIC

CUSTOMER PART#

XX = ± .01
 XXX = ± .005
 XXXX = ± .0005
 ANGLES = ± 1'
 INCH [METRIC]
 FRACTION = ± 1/32

CARTER MANUFACTURING IS
 NOT RESPONSIBLE FOR
 TYPOGRAPHICAL ERRORS

CARTER MANUFACTURING CO., INC.

GRAND HAVEN, MICHIGAN 49417

ENGINEERING CHANGE ORDER NOTE

REVISION

PART NAME: ASSEMBLY

PRODUCT TYPE: SC

C

AUTHOR BY

DRAWN BY

CHK'D BY

SALES

MATERIAL

HG

AJH

MD

KR

NOTED

REVISION BY

DATE

DATE

DATE

DATE

SHEET

SGW

6/23/2020

8/10/2001

6/22/2020

5/5/2017

1 OF 2