

LOAD RATINGS	
RATING	Lbs
RADIAL BASIC DYNAMIC	1,350
DYNAMIC THRUST LOAD	370
MAXIMUM STATIC CAPACITY	600

NOTES:
 1. BALL BEARINGS COME PRE-PACKED WITH GREASE

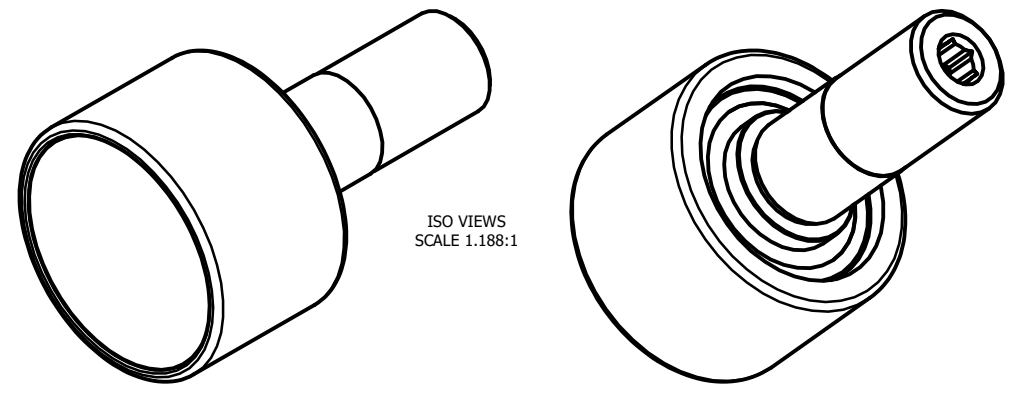

ISO VIEWS
 SCALE 1.188:1

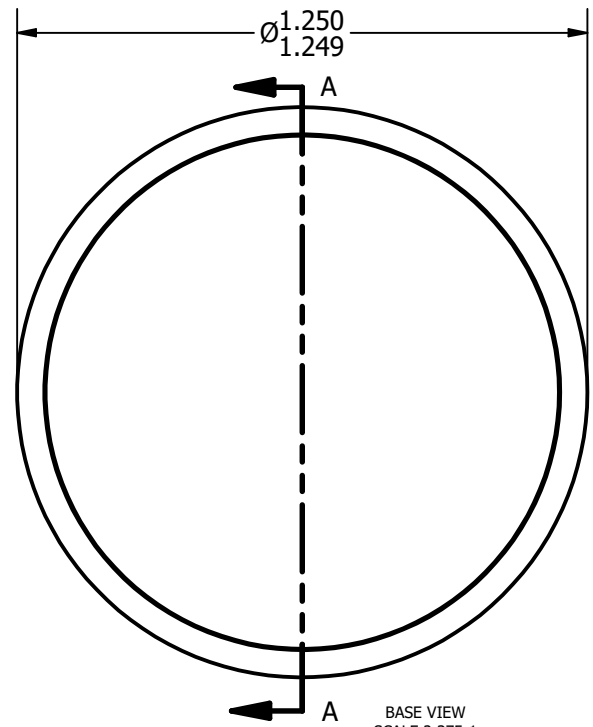

BASE VIEW
 SCALE 2.375:1

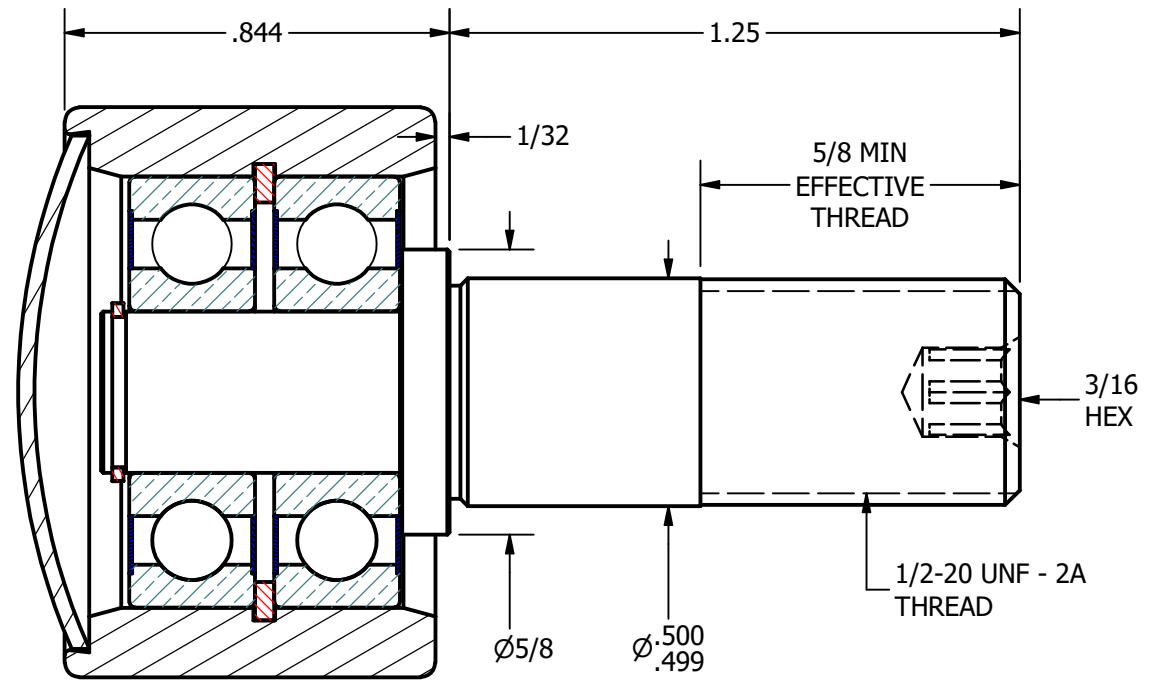

SECTION A-A
 SCALE 2.375:1

MATERIAL NOTES:
 OUTER - BEARING STEEL, HEAT TREATED
 STUD - COLD ROLLED STEEL
 BEARING ASSY. - 609.2RS
 SNAP RINGS - SPRING STEEL
 END CAP - COLD ROLLED STEEL

CUSTOMER PART#	.XX = ± .01 .XXX = ± .005 .XXXX = ± .0005 ANGLES = ± 1° INCH [METRIC]
CHANGE NOTE:	

CARTER MANUFACTURING IS NOT RESPONSIBLE FOR TYPOGRAPHICAL ERRORS	
REVISION	
A	AUTHOR. BY
DB	SGW
REV. BY	DATE
SGW	3/24/2009

CARTER MANUFACTURING CO., INC.					
GRAND HAVEN, MICHIGAN 49417					
PART NAME: ASSEMBLY			SHEET 1 OF 2		
REV.	BY	DATE	CHK'D BY	SALES	MATERIAL
A	DB	3/24/2009	MD	KR	NOTED