

NOTES:

1. BUSHING IS IMPREGNATED WITH OIL
2. ALL EXPOSED STEEL SURFACES HAVE BLACK OXIDE

MS NO.

NSN NO.

DRAWING NO.

NYR-96

ISO VIEW  
SCALE .625 : 1

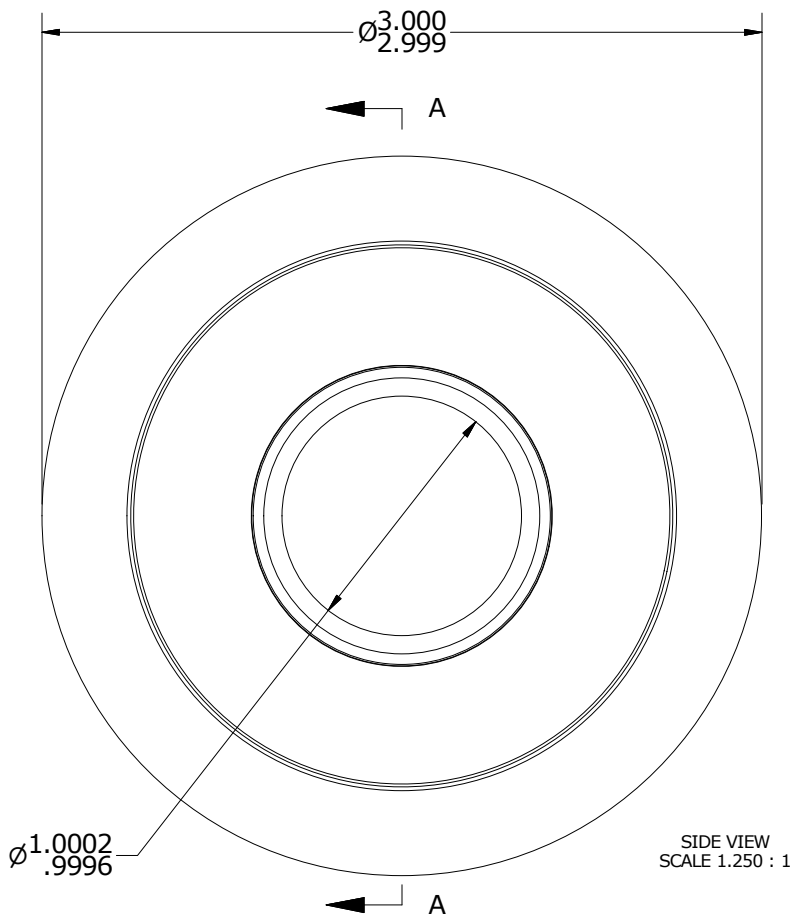
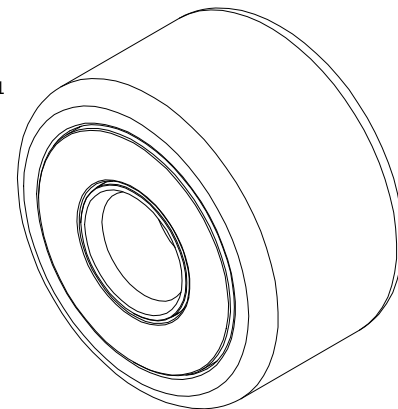

SIDE VIEW  
SCALE 1.250 : 1

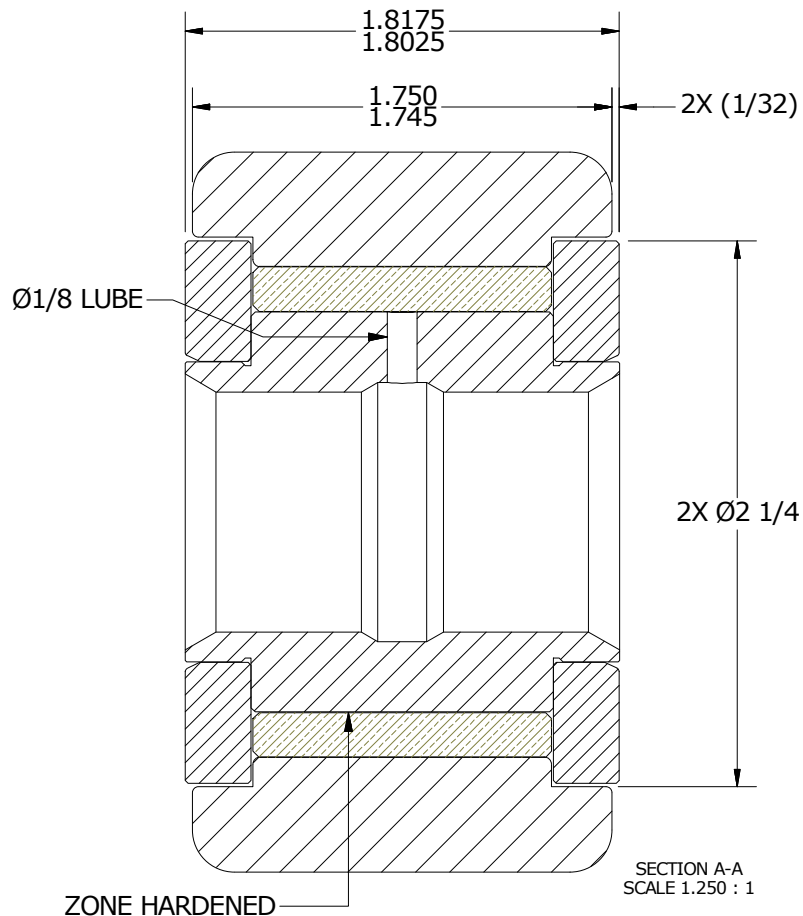

SECTION A-A  
SCALE 1.250 : 1

MATERIAL NOTES:

- OUTER RING - BEARING STEEL, HEAT TREATED
- INNER RING - BEARING STEEL, ZONE HARDENED
- WASHERS - COLD ROLLED STEEL, HEAT TREATED
- BUSHING - SINTERED BRONZE

CUSTOMER PART#

XX = ± .01  
XXX = ± .005  
XXXX = ± .0005  
ANGLES = ± 1'  
INCH [METRIC]  
FRACTION = ± 1/32

CARTER MANUFACTURING IS NOT RESPONSIBLE FOR TYPOGRAPHICAL ERRORS

**CARTER MANUFACTURING CO., INC.**

GRAND HAVEN, MICHIGAN 49417

ENGINEERING CHANGE ORDER NOTE

REVISION

PART NAME: ASSEMBLY

A

AUTHOR BY  
HG

DRAWN BY  
SGW

CHK'D BY  
MD

SALES  
KR

MATERIAL  
NOTED

REVISION BY  
SGW

DATE  
10/12/2016

DATE  
10/11/2016

DATE  
10/12/2016

DATE  
10/12/2016

SHEET  
1 OF 2