

NOTES:

- 1. BUSHING IS IMPREGNATED WITH OIL
- 2. ALL EXPOSED STEEL SURFACES HAVE BLACK OXIDE

ISO VIEW  
SCALE .750 : 1

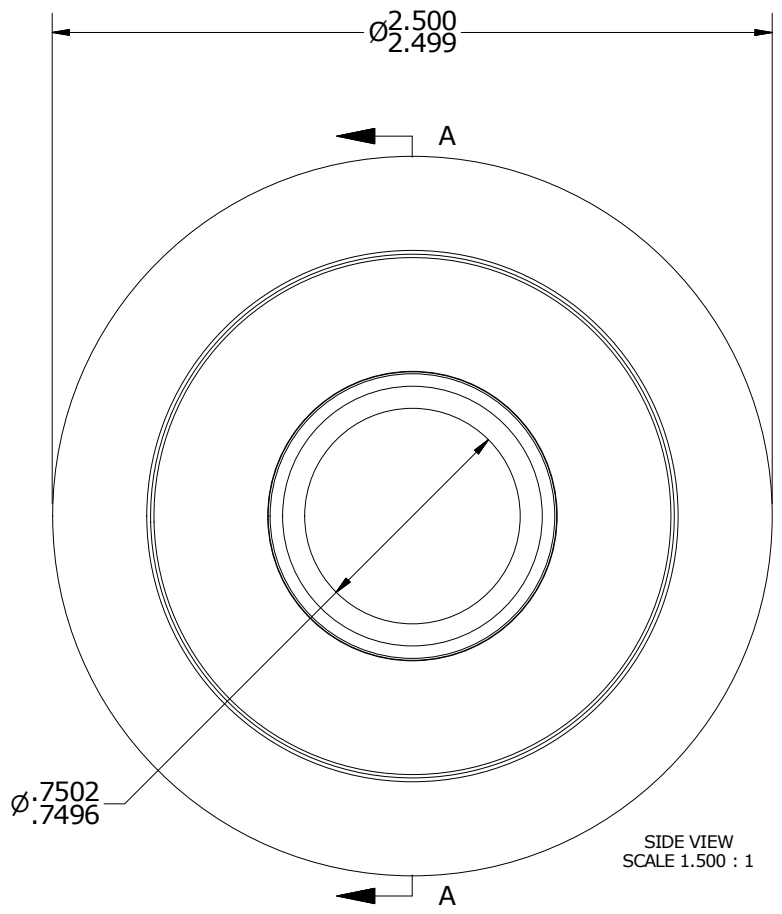
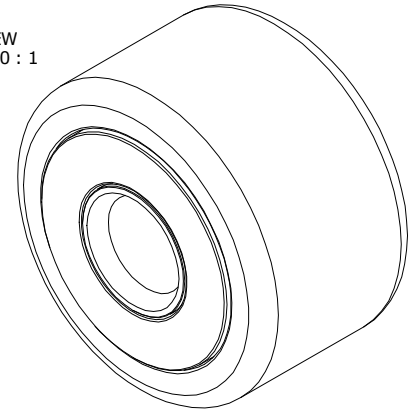

SIDE VIEW  
SCALE 1.500 : 1

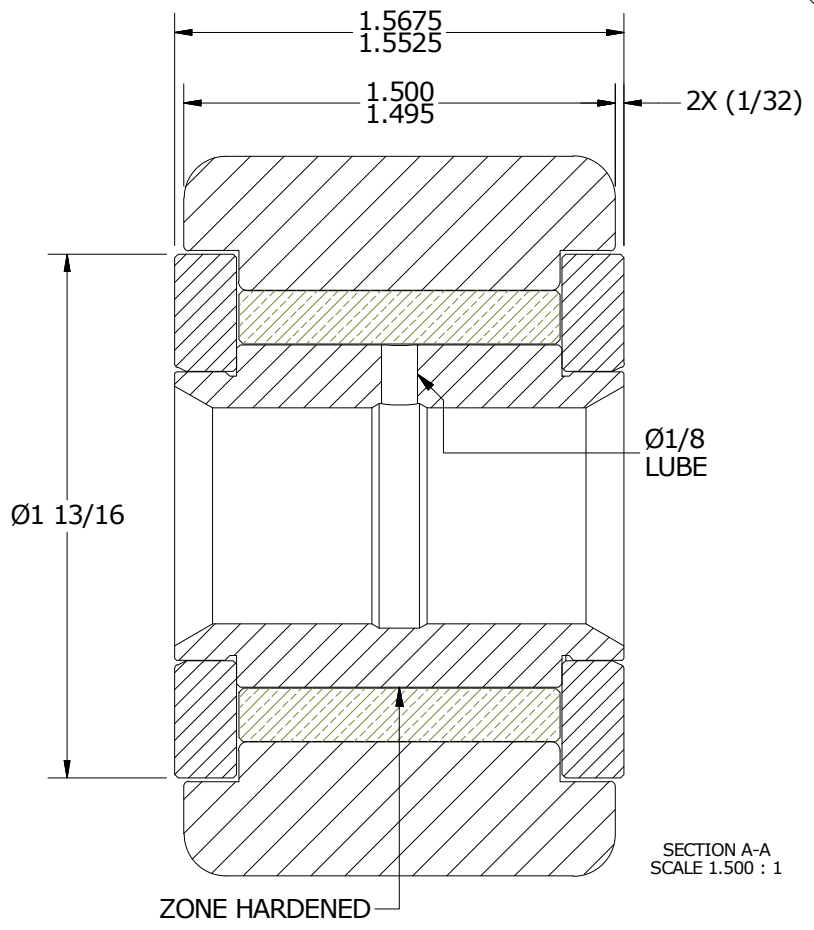

SECTION A-A  
SCALE 1.500 : 1

MATERIAL NOTES:

- OUTER RING - BEARING STEEL, HEAT TREATED
- INNER RING - BEARING STEEL, ZONE HARDENED
- WASHERS - COLD ROLLED STEEL, HEAT TREATED
- BUSHING - SINTERED BRONZE

CUSTOMER PART#

XX =  $\pm .01$   
 XXX =  $\pm .005$   
 XXXX =  $\pm .0005$   
 ANGLES =  $\pm 1'$   
 INCH [METRIC]  
 FRACTION =  $\pm 1/32$

CARTER MANUFACTURING IS NOT RESPONSIBLE FOR TYPOGRAPHICAL ERRORS

**CARTER MANUFACTURING CO., INC.**  
 GRAND HAVEN, MICHIGAN 49417

ENGINEERING CHANGE ORDER NOTE

REVISION

PART NAME: ASSEMBLY

<b>A</b>	AUTHOR BY	DRAWN BY	CHK'D BY	SALES	MATERIAL
	HG	SGW	MD	KR	NOTED
REVISION BY	DATE	DATE	DATE	DATE	SHEET
SGW	12/15/2016	12/12/2016	12/13/2016	12/13/2016	1 OF 2