

NOTES:

1. BUSHING IS IMPREGNATED WITH OIL
2. ALL EXPOSED SURFACES HAVE BLACK OXIDE

MS NO.

NSN NO.

DRAWING NO.

NYR-56

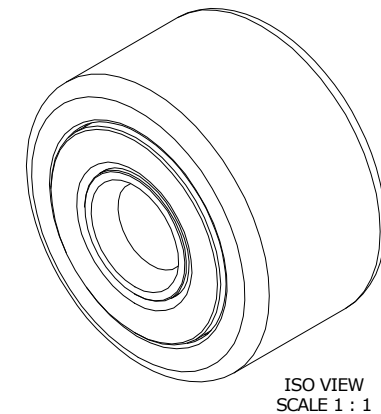
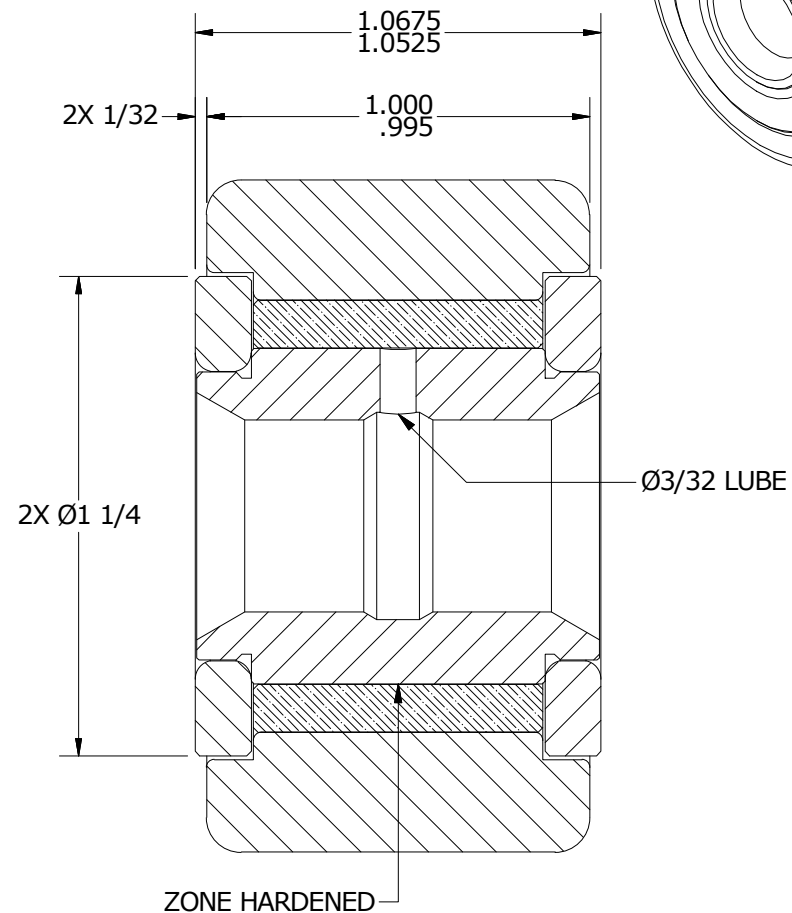
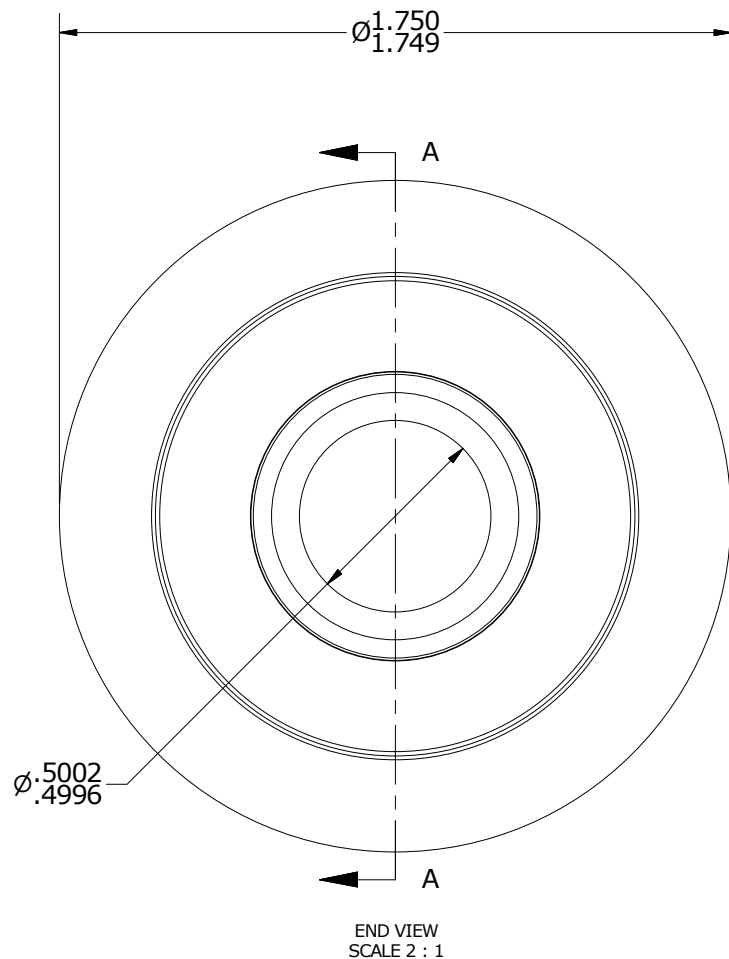

MATERIAL NOTES:

- OUTER RACE - BEARING STEEL, HEAT TREATED
- INNER RACE - BEARING STEEL, ZONE HARDENED
- WASHERS - BEARING STEEL, HEAT TREATED
- BUSHING - SINTERED BRONZE

CUSTOMER PART#

XX = ± .01
 XXX = ± .005
 XXXX = ± .0005
 ANGLES = ± 1'
 INCH [METRIC]
 FRACTION = ± 1/32

CARTER MANUFACTURING IS NOT RESPONSIBLE FOR TYPOGRAPHICAL ERRORS

CARTER MANUFACTURING CO., INC.

GRAND HAVEN, MICHIGAN 49417

ENGINEERING CHANGE ORDER NOTE

REVISION

PART NAME: ASSEMBLY

A

AUTHOR BY

DRAWN BY

CHK'D BY

SALES

MATERIAL

HG

MD

SGW

KR

NOTED

REVISION BY

DATE

DATE

DATE

DATE

SHEET

MD

11/22/2017

11/21/2017

11/22/2017

11/22/2017

1 OF 2