

- NOTES:  
 1. BUSHING IS IMPREGNATED WITH OIL  
 2. ALL EXPOSED STEEL SURFACES HAVE BLACK OXIDE

ISO VIEW  
 SCALE 1.125 : 1

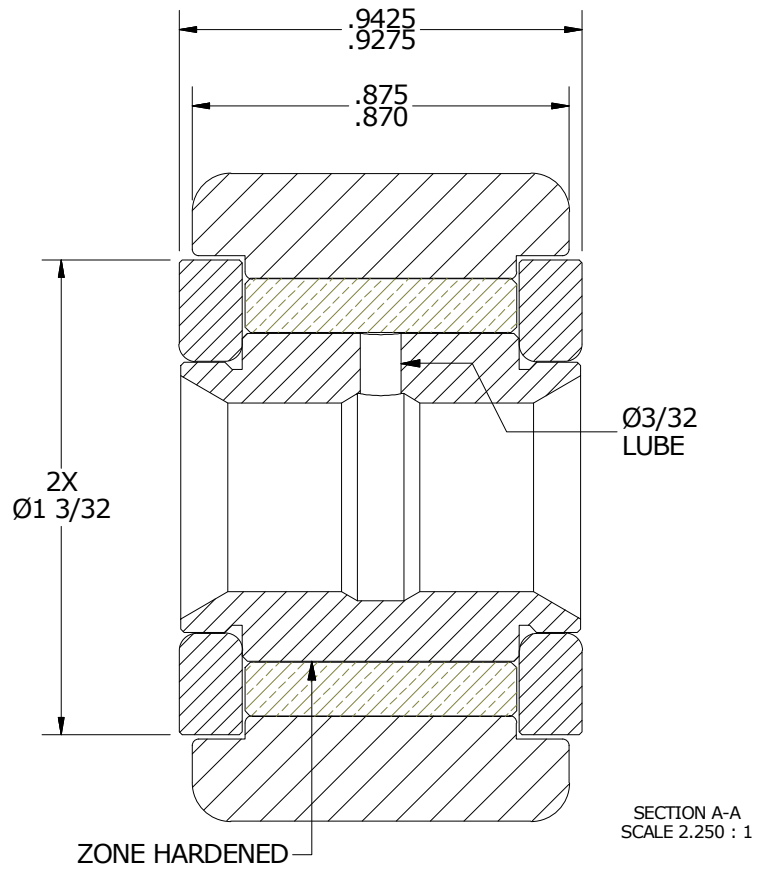
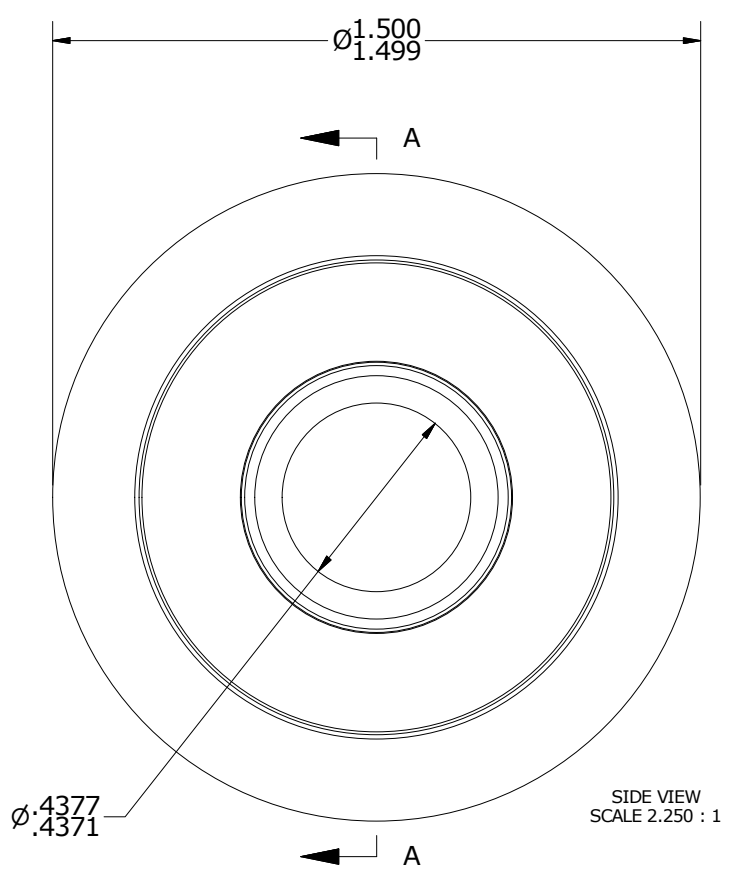
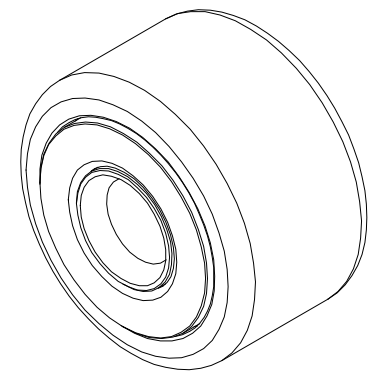

MATERIAL NOTES:  
 OUTER RING - BEARING STEEL, HEAT TREATED  
 INNER RING - BEARING STEEL, ZONE HARDENED  
 BUSHING - SINTERED BRONZE  
 WASHER(S) - COLD ROLLED STEEL, HEAT TREATED\*  
 \*(DEPENDING ON MATERIAL AVAILABILITY, MAY BE CONSTRUCTED FROM BEARING STEEL)

CUSTOMER PART#	XX = ± .01 XXX = ± .005 XXXX = ± .0005 ANGLES = ± 1' INCH [METRIC] FRACTION = ± 1/32
ENGINEERING CHANGE ORDER NOTE	

CARTER MANUFACTURING IS NOT RESPONSIBLE FOR TYPOGRAPHICAL ERRORS		<b>CARTER MANUFACTURING CO., INC.</b> GRAND HAVEN, MICHIGAN 49417			
REVISION		PART NAME: ASSEMBLY			
<b>A</b>	AUTHOR BY HG	DRAWN BY SGW	CHK'D BY MD	SALES KR	MATERIAL NOTED
REVISION BY SGW	DATE 11/10/2016	DATE 11/8/2016	DATE 11/9/2016	DATE 11/11/2016	SHEET 1 OF 2