

NOTES:

1. BUSHING IS IMPREGNATED WITH OIL
2. ALL EXPOSED STEEL SURFACES HAVE BLACK OXIDE

ISO VIEW
SCALE 2.250 : 1

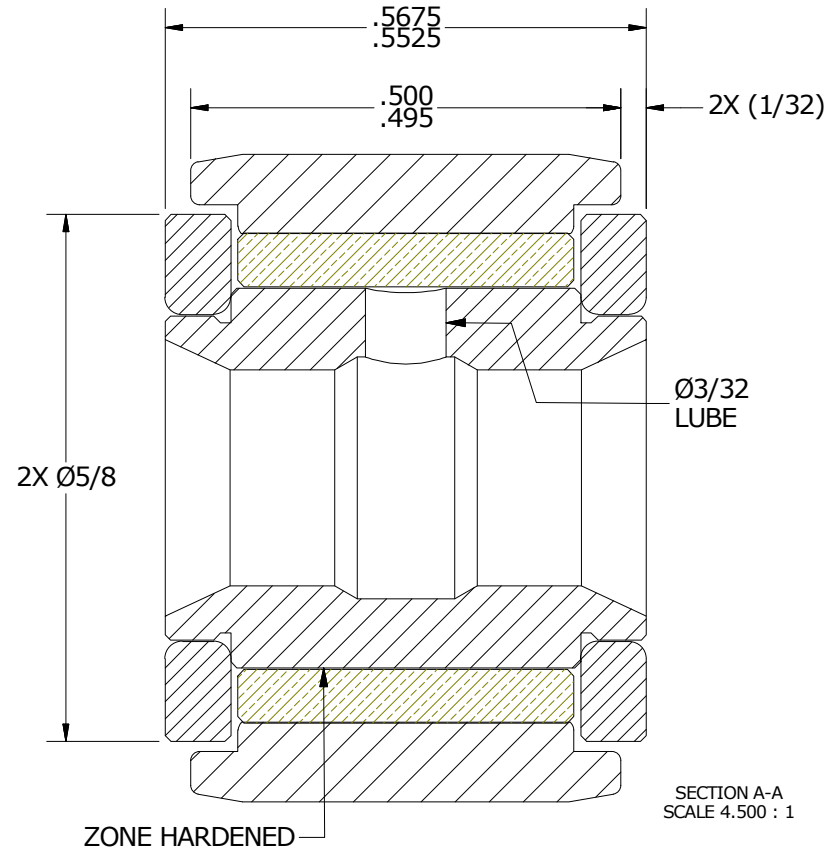
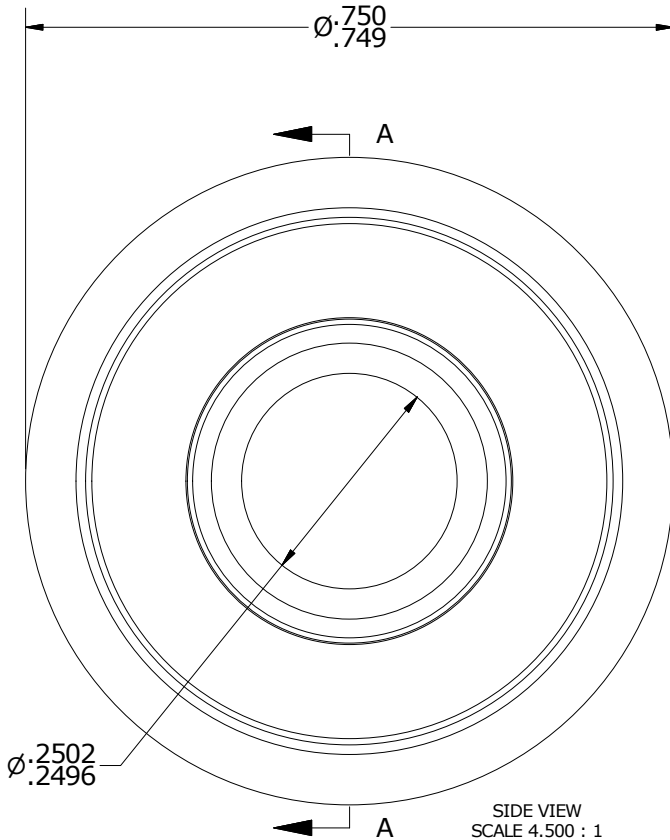
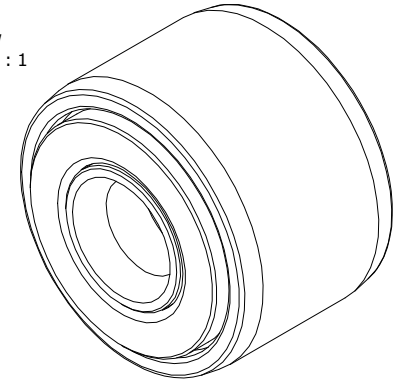

MATERIAL NOTES:

OUTER RING - BEARING STEEL, HEAT TREATED
INNER RING - BEARING STEEL, ZONE HARDENED
BUSHING - SINTERED BRONZE
WASHER(S) - BEARING STEEL, HEAT TREATED

CUSTOMER PART#

XX = ± .01
XXX = ± .005
XXXX = ± .0005
ANGLES = ± 1'
INCH [METRIC]
FRACTION = ± 1/32

CARTER MANUFACTURING IS
NOT RESPONSIBLE FOR
TYPOGRAPHICAL ERRORS

CARTER MANUFACTURING CO., INC.

GRAND HAVEN, MICHIGAN 49417

ENGINEERING CHANGE ORDER NOTE

REVISION

PART NAME: ASSEMBLY

A

AUTHOR BY
HG

DRAWN BY
SGW

CHK'D BY
MD

SALES
KR

MATERIAL
NOTED

REVISION BY
SGW

DATE
5/5/2017

DATE
5/2/2017

DATE
5/4/2017

DATE
5/5/2017

SHEET
1 OF 2