

NOTES:

1. BUSHING IS IMPREGNATED WITH OIL
2. ALL EXPOSED STEEL SURFACES HAVE BLACK OXIDE

MS NO.

NSN NO.

DRAWING NO.

NYR-128

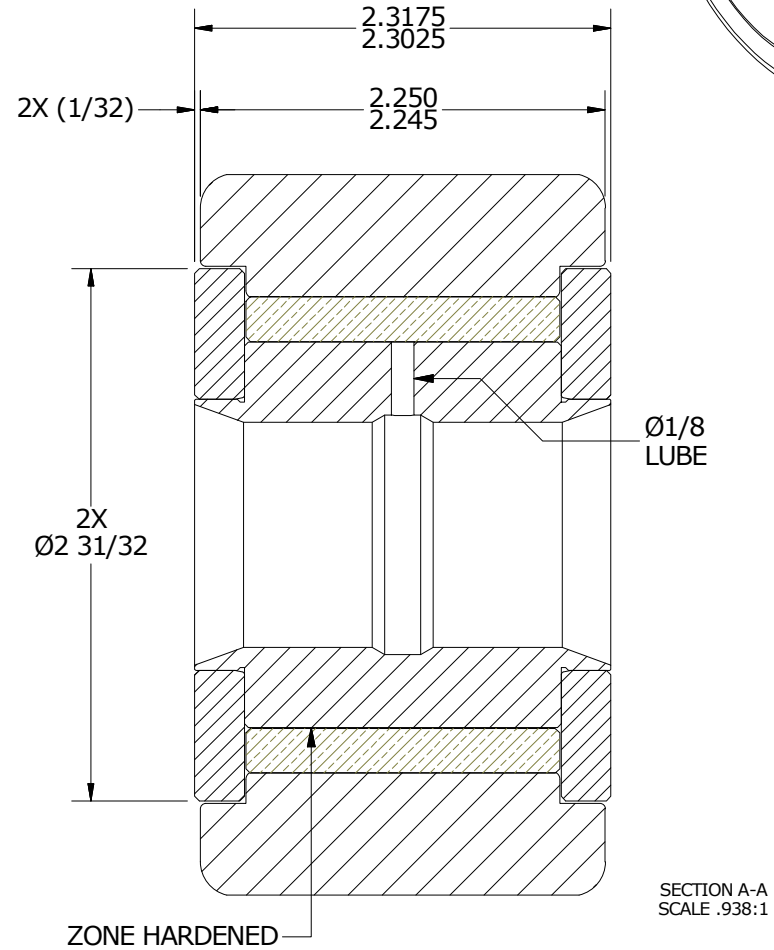
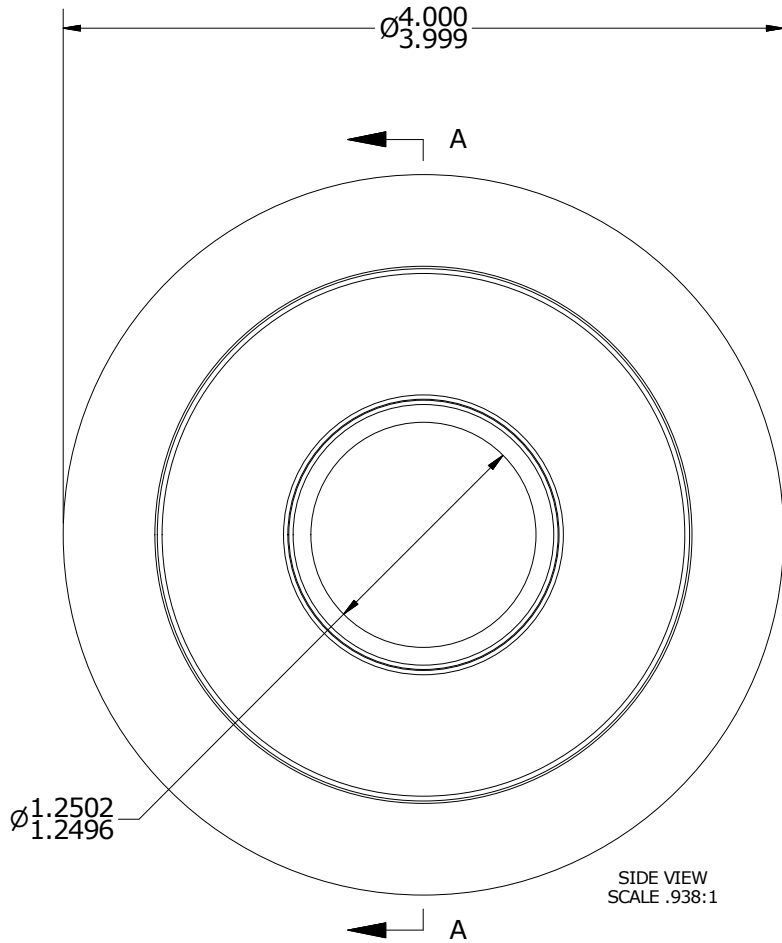
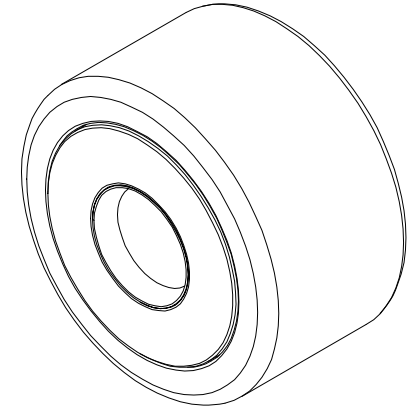

MATERIAL NOTES:

OUTER RING - BEARING STEEL, HEAT TREATED
 INNER RING - BEARING STEEL, ZONE HARDENED
 WASHERS - COLD ROLLED STEEL, HEAT TREATED
 BUSHING - SINTERED BRONZE

CUSTOMER PART#

XX = $\pm .01$
 XXX = $\pm .005$
 XXXX = $\pm .0005$
 ANGLES = $\pm 1'$
 INCH [METRIC]
 FRACTION = $\pm 1/32$

CARTER MANUFACTURING IS
 NOT RESPONSIBLE FOR
 TYPOGRAPHICAL ERRORS

CARTER MANUFACTURING CO., INC.

GRAND HAVEN, MICHIGAN 49417

ENGINEERING CHANGE ORDER NOTE

REVISION

PART NAME: ASSEMBLY

A

AUTHOR BY

DRAWN BY

CHK'D BY

SALES

MATERIAL

HG

SGW

MD

KR

NOTED

REVISION BY

DATE

DATE

DATE

DATE

SHEET

SGW

1/2/2017

12/20/2016

12/20/2016

12/20/2016

1 OF 2