

- NOTES:
 1. BUSHING IS IMPREGNATED WITH OIL
 2. ALL EXPOSED STEEL SURFACES HAVE BLACK OXIDE

MS NO.

NSN NO.

DRAWING NO.

NYR-112

ISO VIEW
 SCALE .563 : 1

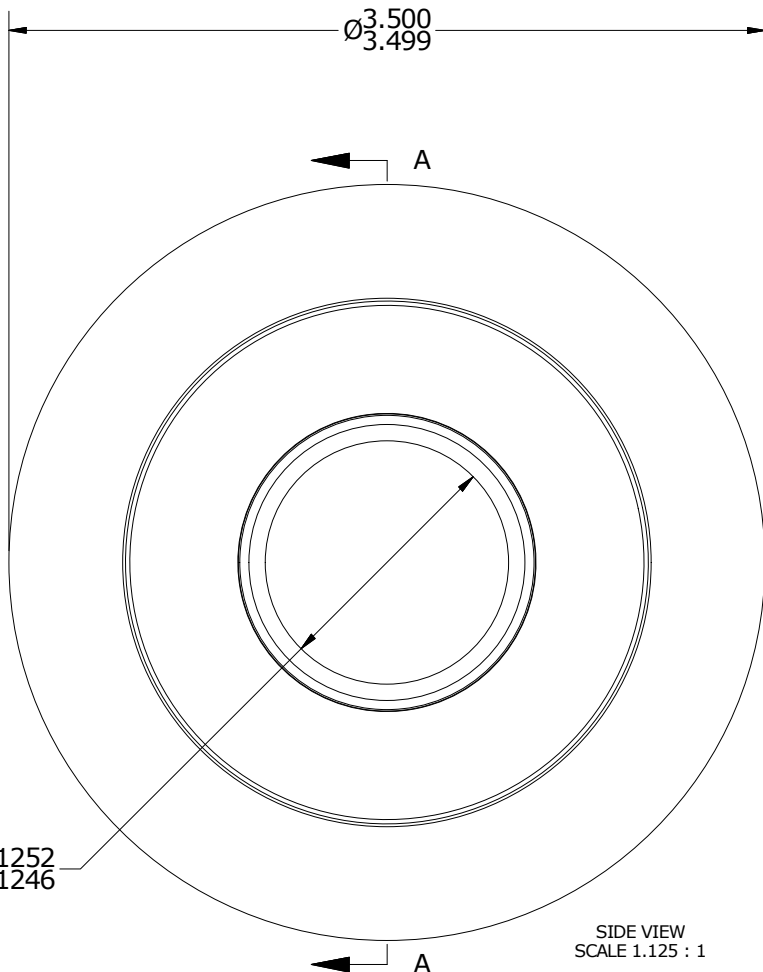
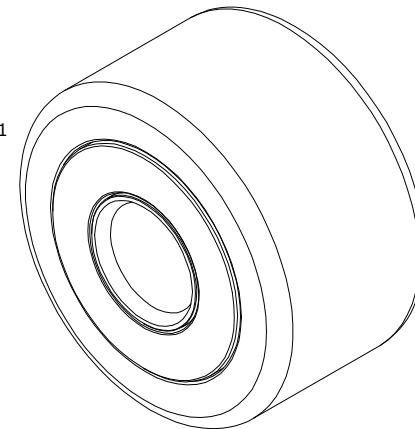

SIDE VIEW
 SCALE 1.125 : 1

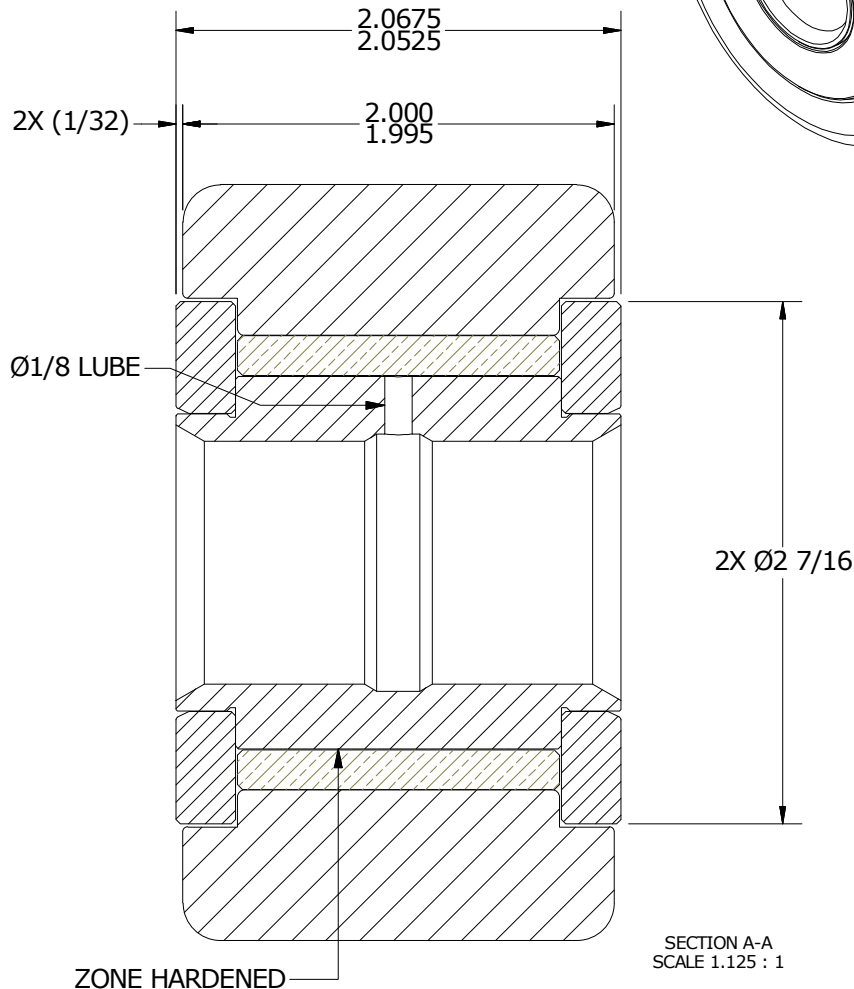

SECTION A-A
 SCALE 1.125 : 1

MATERIAL NOTES:

OUTER RING - BEARING STEEL, HEAT TREATED
 INNER RING - BEARING STEEL, ZONE HARDNED
 WASHERS - COLD ROLLED STEEL, HEAT TREATED
 BUSHING - SINTERED BRONZE

CUSTOMER PART#

XX = ± .01
 XXX = ± .005
 XXXX = ± .0005
 ANGLES = ± 1'
 INCH [METRIC]
 FRACTION = ± 1/32

CARTER MANUFACTURING IS
 NOT RESPONSIBLE FOR
 TYPOGRAPHICAL ERRORS

CARTER MANUFACTURING CO., INC.

GRAND HAVEN, MICHIGAN 49417

ENGINEERING CHANGE ORDER NOTE

REVISION

PART NAME: ASSEMBLY

A

AUTHOR BY

DRAWN BY

CHK'D BY

SALES

MATERIAL

HG

SGW

MD

KR

NOTED

REVISION BY

DATE

DATE

DATE

DATE

SHEET

SGW

10/12/2016

10/11/2016

10/12/2016

10/12/2016

1 OF 2