

NOTES:

1. BUSHING IS IMPREGNATED WITH OIL
2. ALL EXPOSED STEEL SURFACES HAVE BLACK OXIDE

MS NO.

NSN NO.

DRAWING NO.

NYR-104

ISO VIEW
SCALE .593 : 1

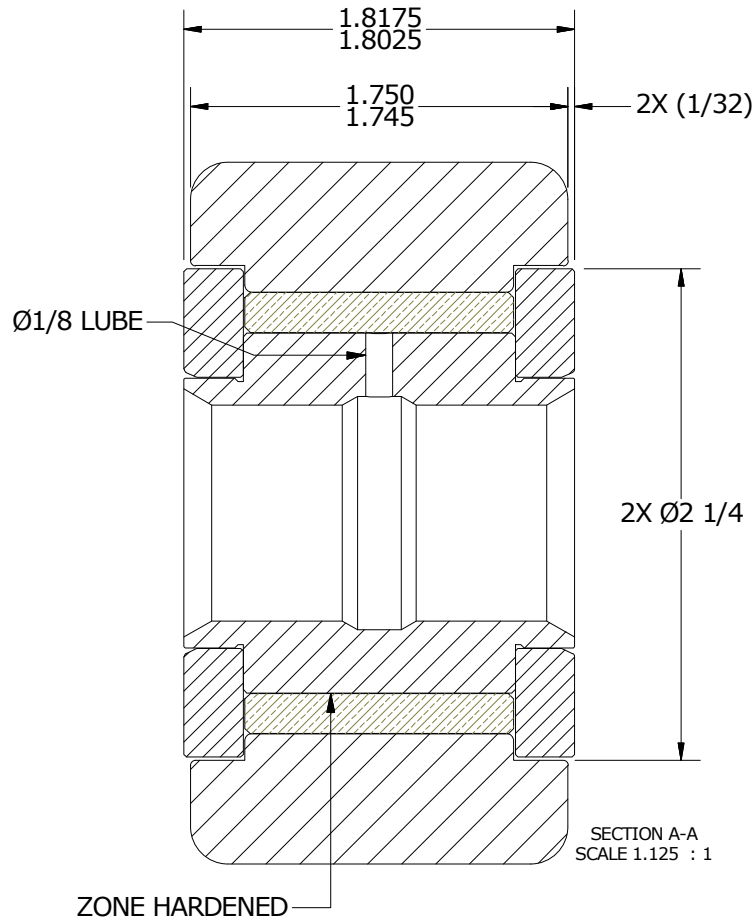
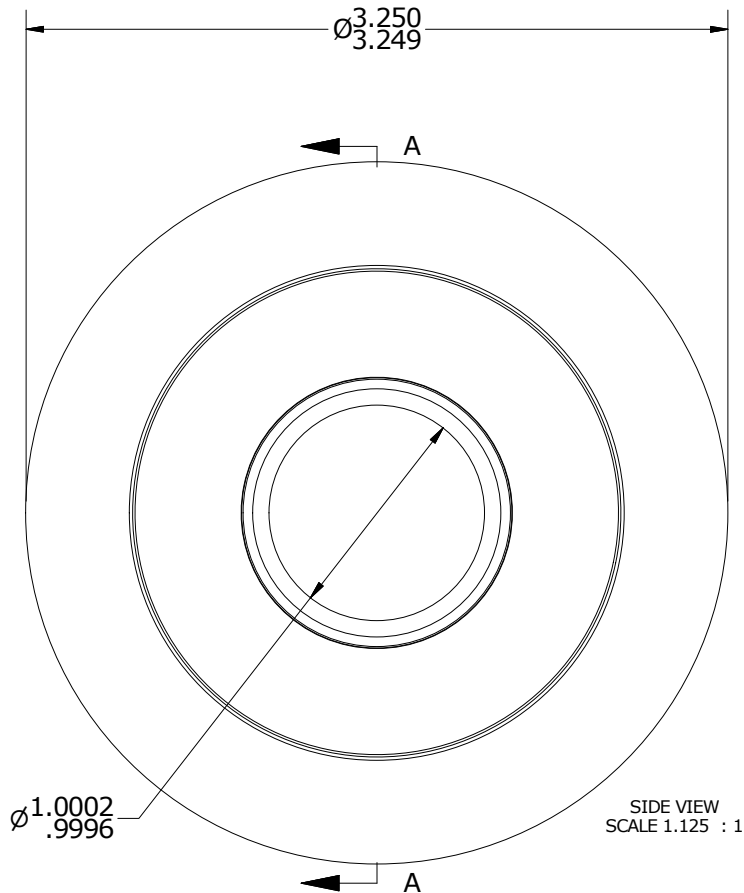
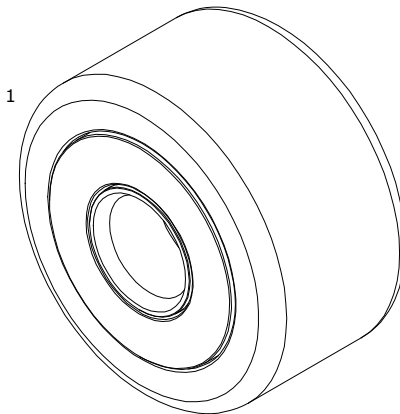

MATERIAL NOTES:

OUTER RING - BEARING STEEL, HEAT TREATED
INNER RING - BEARING STEEL, ZONE HARDENED
WASHERS - COLD ROLLED STEEL, HEAT TREATED
BUSHING - SINTERED BRONZE

CUSTOMER PART#

XX = ± .01
XXX = ± .005
XXXX = ± .0005
ANGLES = ± 1'
INCH [METRIC]
FRACTION = ± 1/32

CARTER MANUFACTURING IS
NOT RESPONSIBLE FOR
TYPOGRAPHICAL ERRORS

CARTER MANUFACTURING CO., INC.

GRAND HAVEN, MICHIGAN 49417

ENGINEERING CHANGE ORDER NOTE

REVISION

PART NAME: ASSEMBLY

A

AUTHOR BY

DRAWN BY

CHK'D BY

SALES

MATERIAL

HG

SGW

MD

KR

NOTED

REVISION BY

DATE

DATE

DATE

DATE

SHEET

SGW

1/2/2017

12/13/2016

12/21/2016

12/13/2016

1 OF 2