

ISO/ABMA BASIC LOAD RATINGS		
Rating	Newtons	Lbs
DYNAMIC	46,580	10,472
STATIC	92,630	20,824

TRACK ROLLER LOAD RATINGS		
RATING	Newtons	Lbs
DYNAMIC	38,840	8,732
STATIC	65,400	14,703

MAXIMUM CLAMPING TORQUE		
Thread Type	Nm	Inch Lbs
DRY	216	1912
LUBRICATED	108	956

RECOMMENDED MOUNTING HOLE Ø		
Limit	mm	Inch
MIN	28.050	1.1043
MAX	28.075	1.1053

- NOTES:
- BEARING IS PACKED WITH NLGI GRADE 2, LITHIUM BASED GREASE (UNLESS OTHERWISE SPECIFIED)
 - ALL EXPOSED STEEL SURFACES HAVE BLACK OXIDE
 - LIMITING SPEEDS:
 - GREASE = 2,100 RPM
 - OIL = 2,700 RPM

MS NO. _____ NSN NO. _____ DRAWING NO. MCNBE-72-SBX

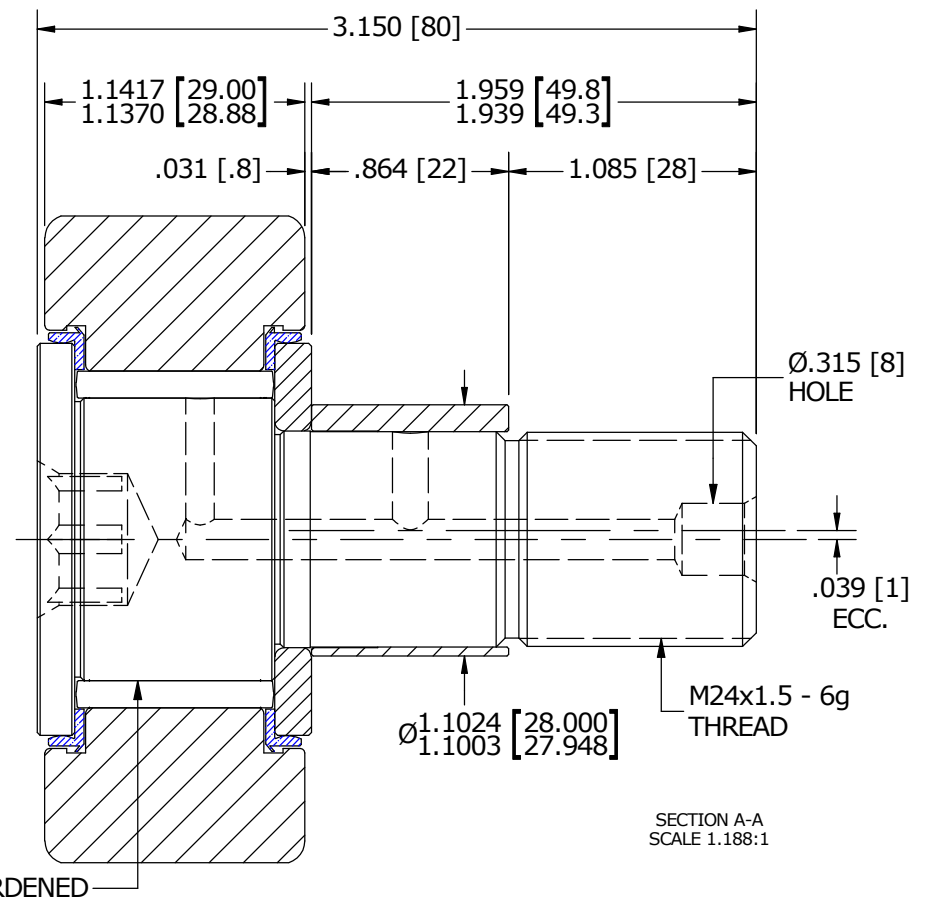
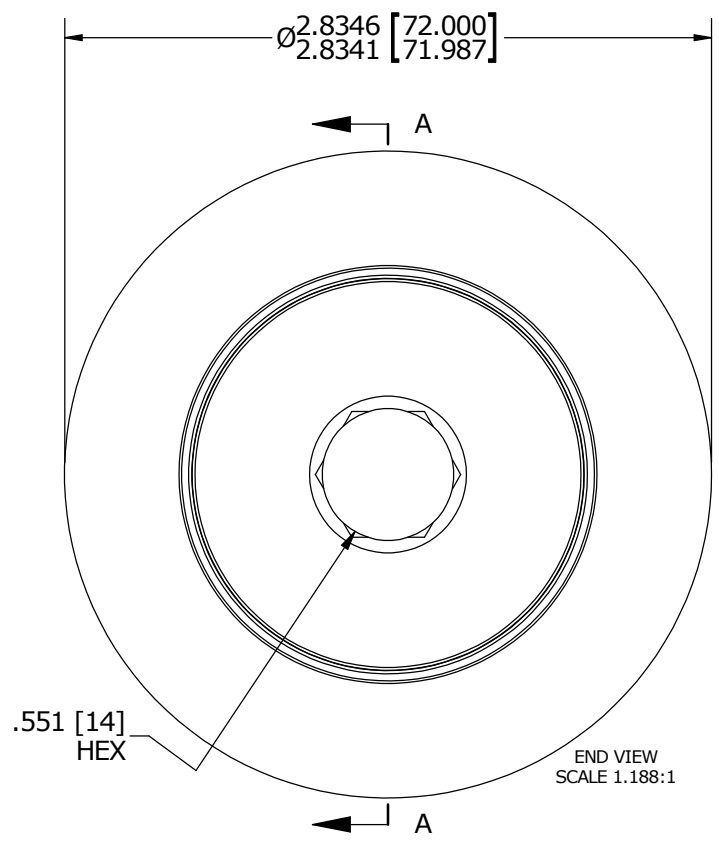
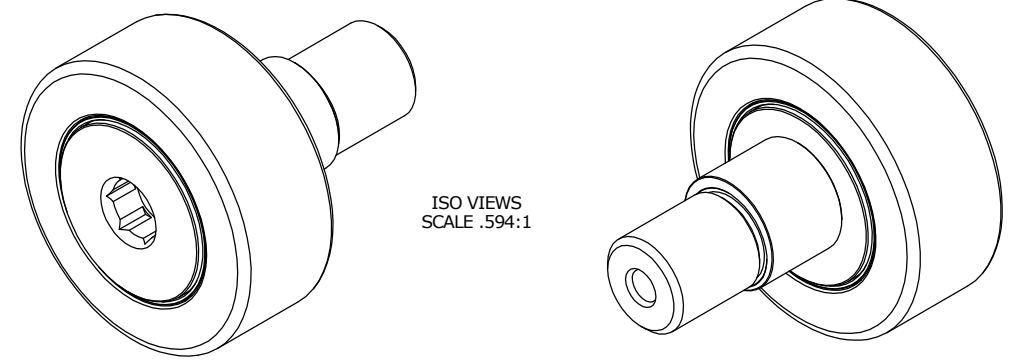

MATERIAL NOTES:

OUTER RACE - BEARING STEEL, HEAT TREATED
 STUD - BEARING STEEL, ZONE HARDENED
 NEEDLE ROLLER - BEARING STEEL, HEAT TREATED
 WASHER - COLD ROLLED STEEL, HEAT TREATED
 ECCENTRIC SLEEVE - COLD ROLLED STEEL
 SEAL - SYNTHETIC

CUSTOMER PART#	XX = ± .01 XXX = ± .005 XXXX = ± .0005 ANGLES = ± 1' INCH [METRIC] FRACTION = ± 1/32
ENGINEERING CHANGE ORDER NOTE	

CARTER MANUFACTURING IS NOT RESPONSIBLE FOR TYPOGRAPHICAL ERRORS		CARTER MANUFACTURING CO., INC. GRAND HAVEN, MICHIGAN 49417			
REVISION		PART NAME: ASSEMBLY			
A	AUTHOR BY HG	DRAWN BY SGW	CHK'D BY MD	SALES KR	MATERIAL NOTED
REVISION BY SGW	DATE 12/12/2015	DATE 11/16/2015	DATE 11/23/2015	DATE 11/19/2015	SHEET 1 OF 2