

ISO/ABMA BASIC LOAD RATINGS		
Rating	Newtons	Lbs
DYNAMIC	30,790	6,922
STATIC	57,670	12,965

TRACK ROLLER LOAD RATINGS		
RATING	Newtons	Lbs
DYNAMIC	25,690	5,775
STATIC	46,700	10,499

MAXIMUM CLAMPING TORQUE		
Thread Type	Nm	Inch Lbs
DRY	118	1,044
LUBRICATED	59	522

RECOMMENDED MOUNTING HOLE Ø		
Limit	mm	Inch
MIN	20.000	.7874
MAX	20.021	.7882

NOTES:

- BEARING IS PACKED WITH NLGI GRADE 2, LITHIUM BASED GREASE (UNLESS OTHERWISE SPECIFIED)
- ALL EXPOSED STEEL SURFACES HAVE BLACK OXIDE
- LIMITING SPEEDS:
 - GREASE = 2,600 RPM
 - OIL = 3,400 RPM

MS NO. _____ NSN NO. _____ DRAWING NO. MCNB-47-SBX

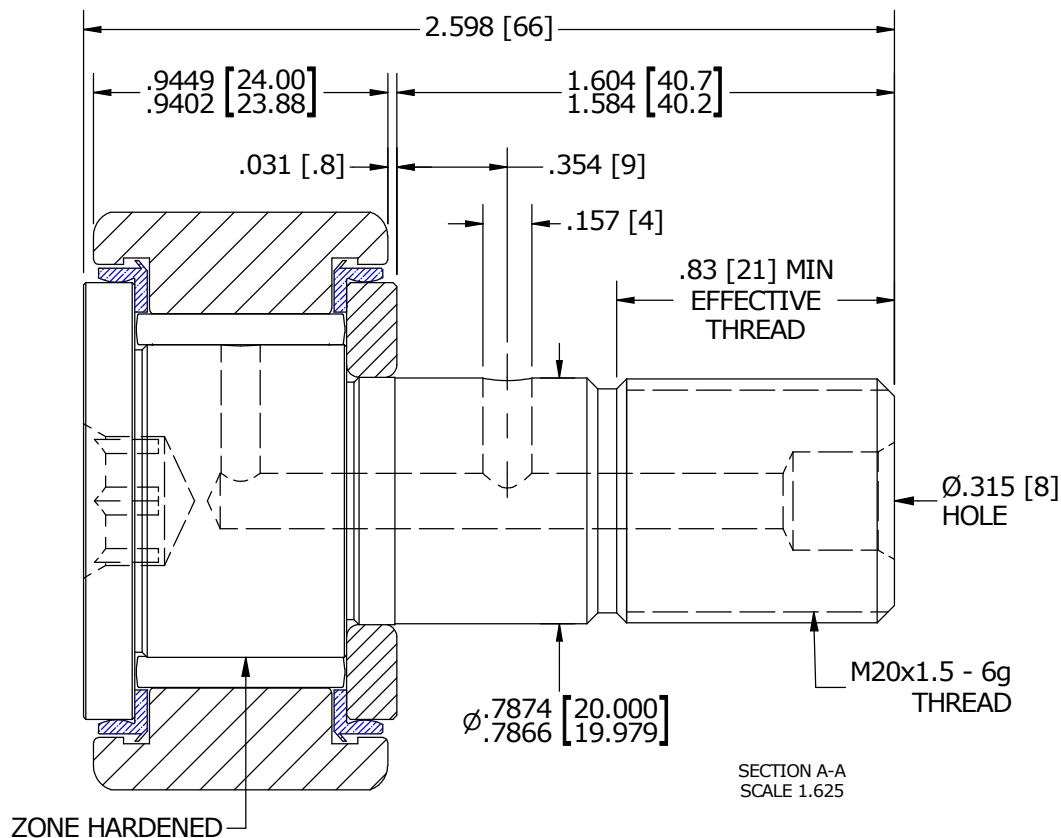
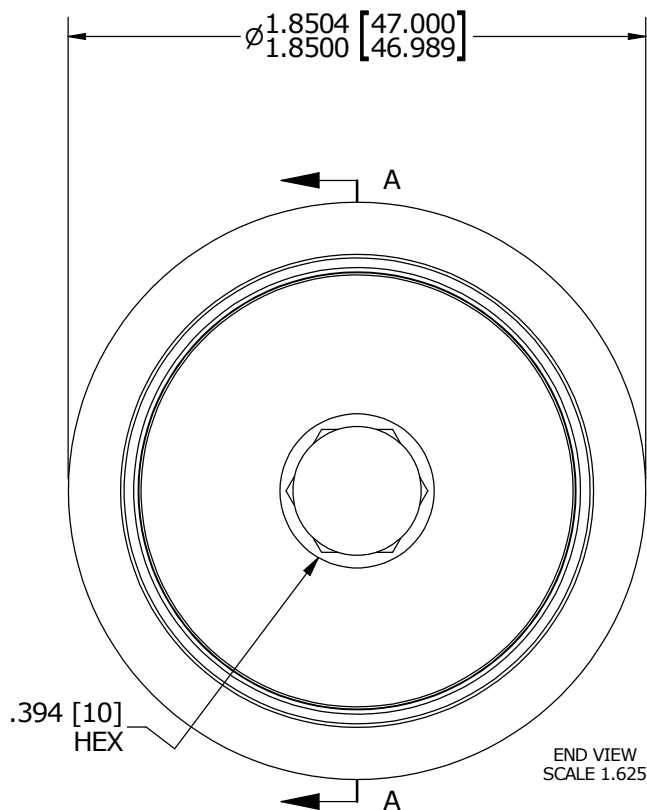
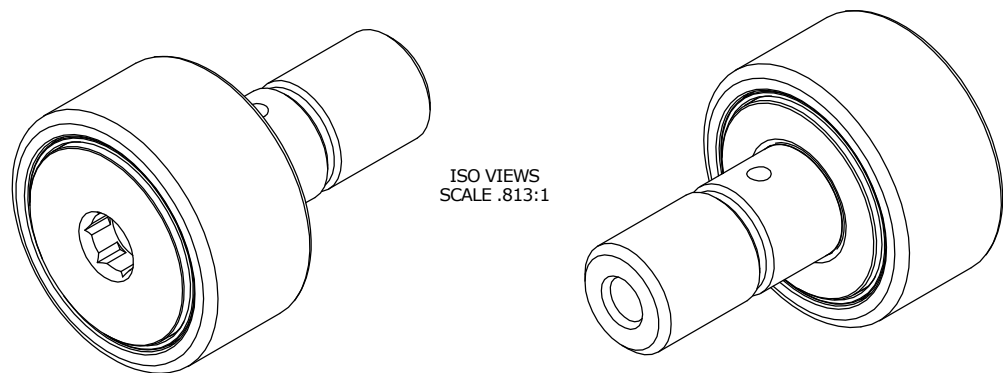

MATERIAL NOTES:

OUTER RACE - BEARING STEEL, HEAT TREATED
 STUD - BEARING STEEL, ZONE HARDENED
 NEEDLE ROLLER - BEARING STEEL, HEAT TREATED
 WASHER - COLD ROLLED STEEL, HEAT TREATED
 SEAL - SYNTHETIC

CUSTOMER PART#

XX = ± .01
 XXX = ± .005
 XXXX = ± .0005
 ANGLES = ± 1'
 INCH [METRIC]
 FRACTION = ± 1/32

CARTER MANUFACTURING IS NOT RESPONSIBLE FOR TYPOGRAPHICAL ERRORS

CARTER MANUFACTURING CO., INC.

GRAND HAVEN, MICHIGAN 49417

ENGINEERING CHANGE ORDER NOTE

REVISION

PART NAME: ASSEMBLY

A

AUTHOR BY

DRAWN BY

CHK'D BY

SALES

MATERIAL

HG

SGW

MD

KR

NOTED

REVISION BY

DATE

DATE

DATE

DATE

SHEET

SGW

2/12/2015

2/2/2015

2/12/2015

2/23/2015

1 OF 2