

ISO/ABMA BASIC LOAD RATINGS		
Rating	Newtons	Lbs
DYNAMIC	30,790	6,922
STATIC	57,670	12,965

TRACK ROLLER LOAD RATINGS		
RATING	Newtons	Lbs
DYNAMIC	25,690	5,775
STATIC	46,700	10,499

MAXIMUM CLAMPING TORQUE		
Thread Type	Nm	Inch Lbs
DRY	118	1,044
LUBRICATED	59	522

RECOMMENDED MOUNTING HOLE Ø		
Limit	mm	Inch
MIN	20.000	.7874
MAX	20.021	.7882

- NOTES:
- BEARING IS PACKED WITH NLGI GRADE 2, LITHIUM BASED GREASE (UNLESS OTHERWISE SPECIFIED)
 - ALL EXPOSED STEEL SURFACES HAVE BLACK OXIDE
 - LIMITING SPEEDS:
 - GREASE = 2,600 RPM
 - OIL = 3,400 RPM

MS NO. _____ NSN NO. _____ DRAWING NO. **MCNB-47-SB**

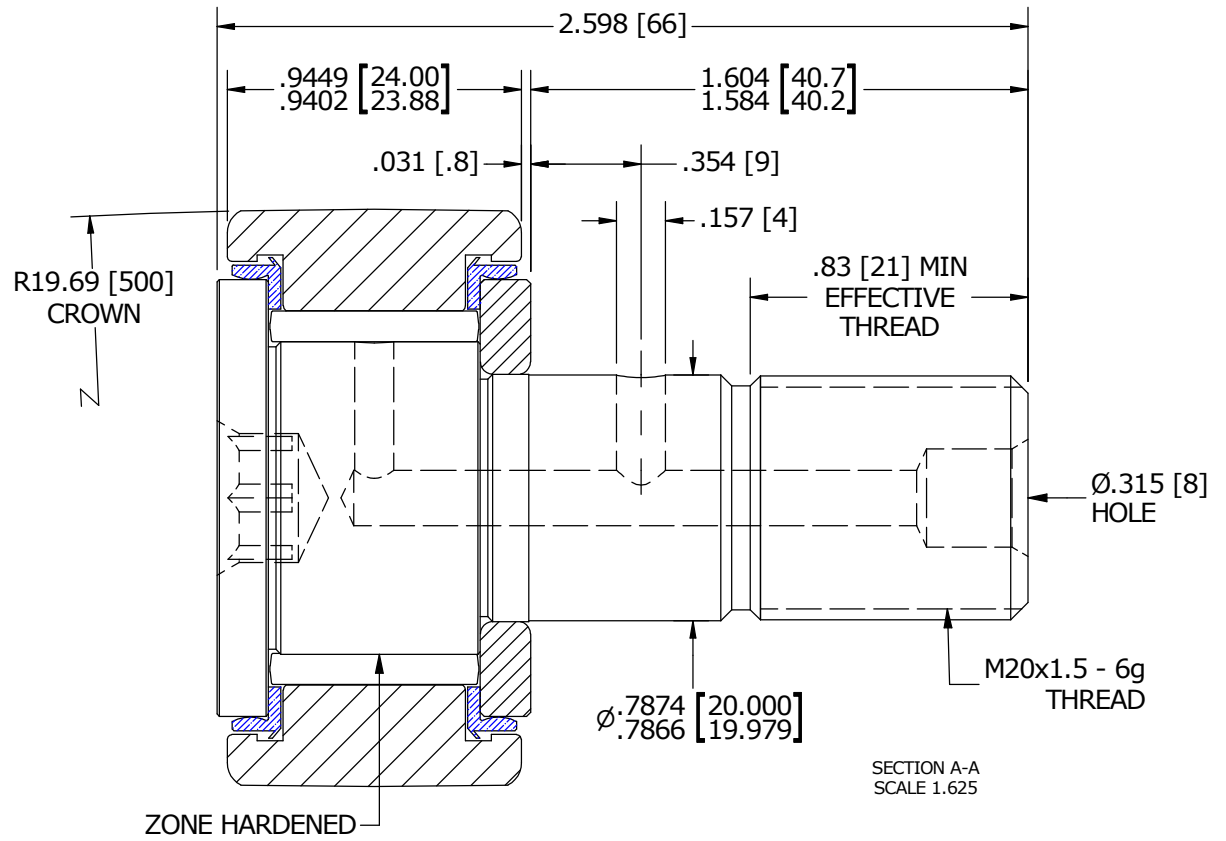
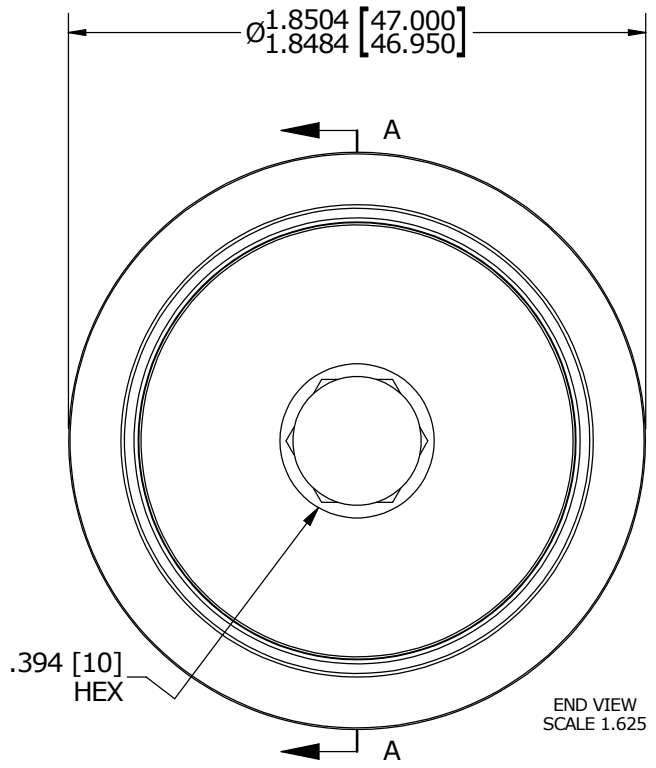
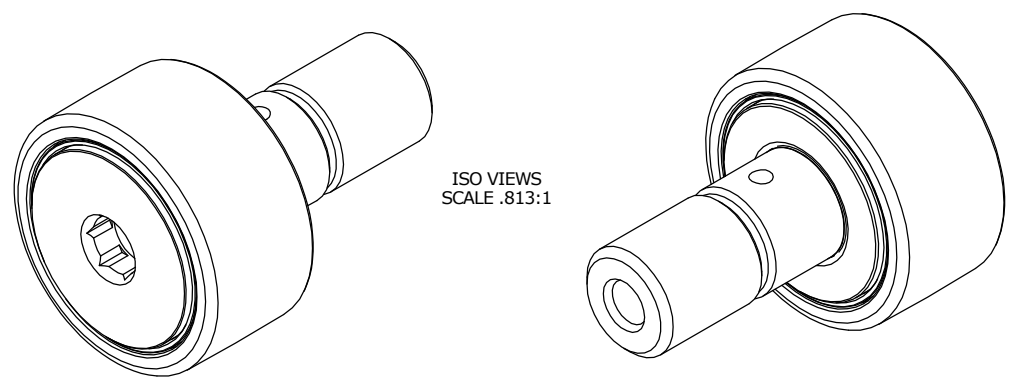

MATERIAL NOTES:

OUTER RACE - BEARING STEEL, HEAT TREATED
 STUD - BEARING STEEL, ZONE HARDENED
 NEEDLE ROLLER - BEARING STEEL, HEAT TREATED
 WASHER - COLD ROLLED STEEL, HEAT TREATED
 SEAL - SYNTHETIC

CUSTOMER PART#	XX = ± .01 XXX = ± .005 XXXX = ± .0005 ANGLES = ± 1' INCH [METRIC] FRACTION = ± 1/32
<i>ENGINEERING CHANGE ORDER NOTE</i>	

CARTER MANUFACTURING IS NOT RESPONSIBLE FOR TYPOGRAPHICAL ERRORS				CARTER MANUFACTURING CO., INC. GRAND HAVEN, MICHIGAN 49417			
<i>REVISION</i>				PART NAME: ASSEMBLY			
C	AUTHOR BY HG	DRAWN BY AJH	CHK'D BY MD	SALES KR	MATERIAL NOTED		
REVISION BY SGW	DATE 2/12/2015	DATE 5/29/2002	DATE 2/12/2015	DATE 2/23/2015	SHEET 1 OF 2		