

ISO/ABMA BASIC LOAD RATINGS		
Rating	Newtons	Lbs
DYNAMIC	23,240	5,225
STATIC	38,540	8,664

TRACK ROLLER LOAD RATINGS		
RATING	Newtons	Lbs
DYNAMIC	19,420	4,366
STATIC	32,200	7,239

MAXIMUM CLAMPING TORQUE		
Thread Type	Nm	Inch Lbs
DRY	85	752
LUBRICATED	42.5	376

RECOMMENDED MOUNTING HOLE Ø		
Limit	mm	Inch
MIN	18.000	.7087
MAX	18.018	.7094

- NOTES:
- BEARING IS PACKED WITH NLGI GRADE 2, LITHIUM BASED GREASE (UNLESS OTHERWISE SPECIFIED)
 - ALL EXPOSED STEEL SURFACES HAVE BLACK OXIDE
 - LIMITING SPEEDS:
 - GREASE = 3,300 RPM
 - OIL = 4,300 RPM

MS NO. _____ NSN NO. _____ DRAWING NO. MCNB-40-SB

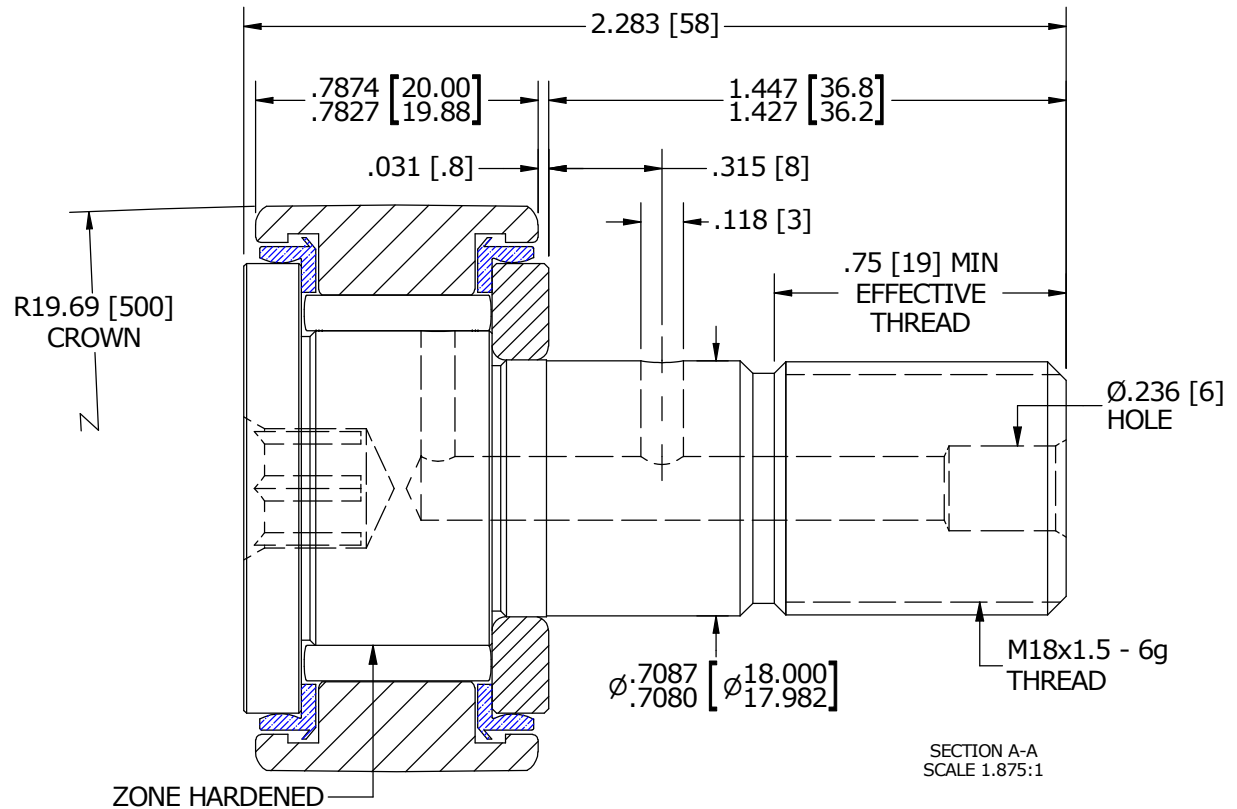
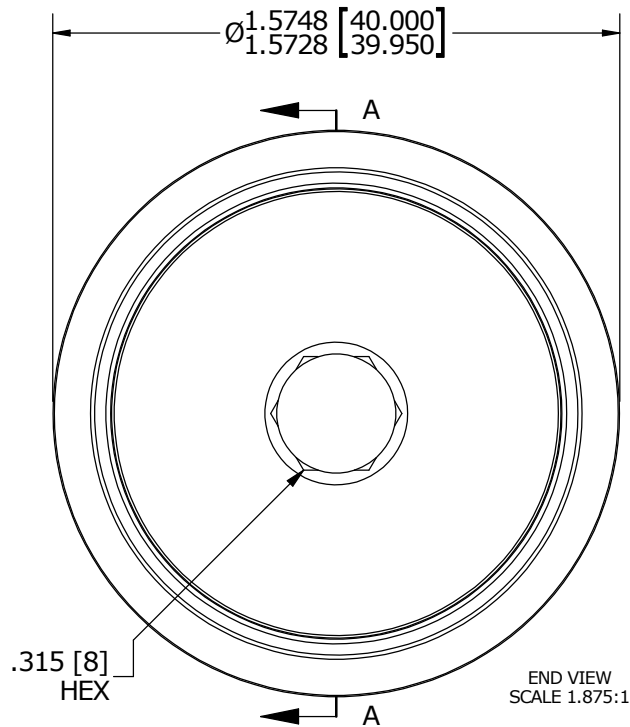
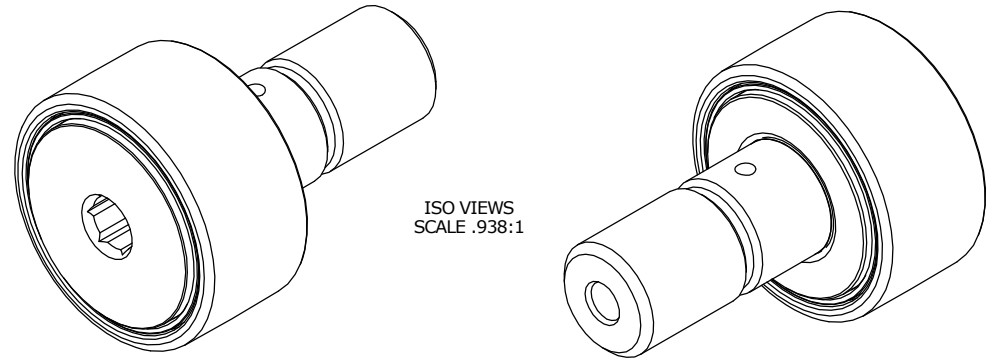

MATERIAL NOTES:

OUTER RACE - BEARING STEEL, HEAT TREATED
 STUD - BEARING STEEL, ZONE HARDENED
 NEEDLE ROLLER - BEARING STEEL, HEAT TREATED
 WASHER - COLD ROLLED STEEL, HEAT TREATED
 SEAL - SYNTHETIC

CUSTOMER PART#

XX = ± .01
 XXX = ± .005
 XXXX = ± .0005
 ANGLES = ± 1'
 INCH [METRIC]
 FRACTION = ± 1/32

CARTER MANUFACTURING IS NOT RESPONSIBLE FOR TYPOGRAPHICAL ERRORS

CARTER MANUFACTURING CO., INC.
 GRAND HAVEN, MICHIGAN 49417

ENGINEERING CHANGE ORDER NOTE

REVISION

PART NAME: ASSEMBLY

REVISION	AUTHOR BY	DRAWN BY	CHK'D BY	SALES	MATERIAL
A	HG	SGW	MD	KR	NOTED
REVISION BY	DATE	DATE	DATE	DATE	SHEET
SGW	2/10/2015	11/25/2014	1/27/2015	8/13/2015	1 OF 2