

ISO/ABMA BASIC LOAD RATINGS		
Rating	Newtons	Lbs
DYNAMIC	8,040	1,807
STATIC	10,490	2,358

TRACK ROLLER LOAD RATINGS		
RATING	Newtons	Lbs
DYNAMIC	6,670	1,499
STATIC	5,100	1,147

MAXIMUM CLAMPING TORQUE		
Thread Type	Nm	Inch Lbs
DRY	8	70.80
LUBRICATED	4	35.40

RECOMMENDED MOUNTING HOLE Ø		
Limit	mm	Inch
MIN	8.000	.3150
MAX	8.015	.3155

**NOTES:**

1. BEARING IS PACKED WITH NLGI GRADE 2, LITHIUM BASED GREASE (UNLESS OTHERWISE SPECIFIED)
2. ALL EXPOSED STEEL SURFACES HAVE BLACK OXIDE
3. LIMITING SPEEDS:
  - A. GREASE = 10,500 RPM
  - B. OIL = 13,500 RPM

MS NO. \_\_\_\_\_ NSN NO. \_\_\_\_\_ DRAWING NO. MCNB-19-SBX

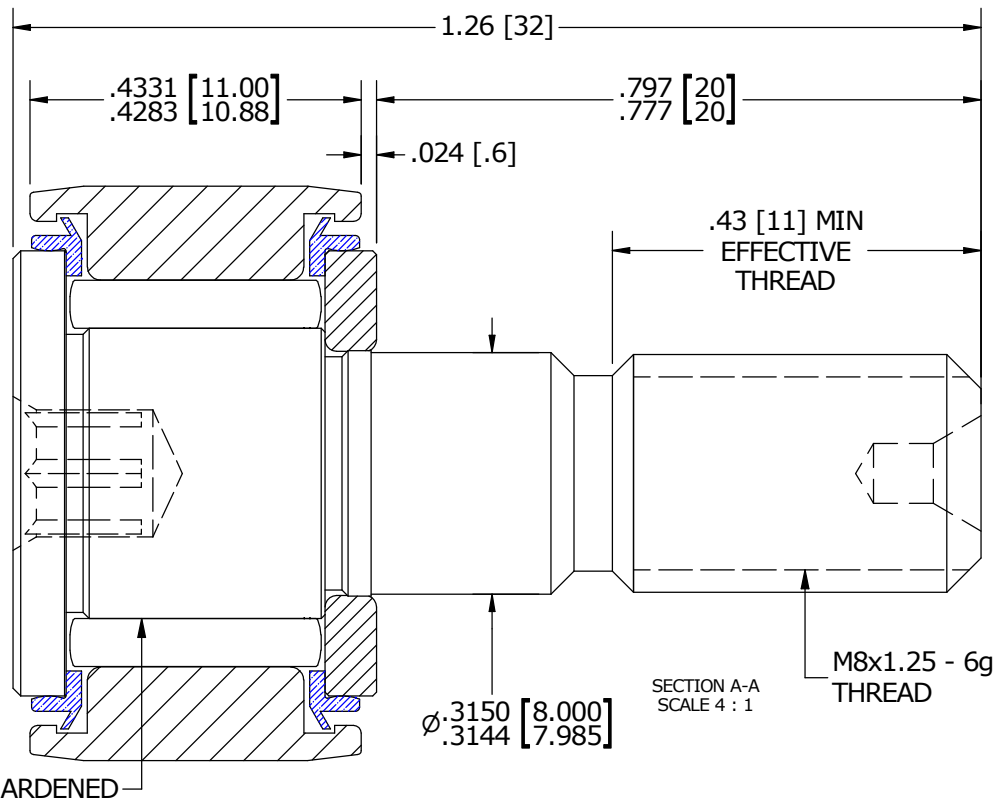
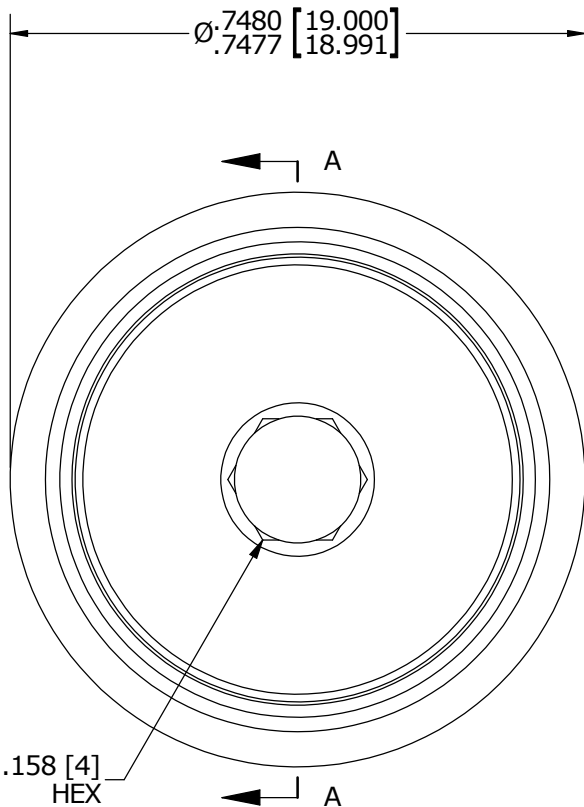
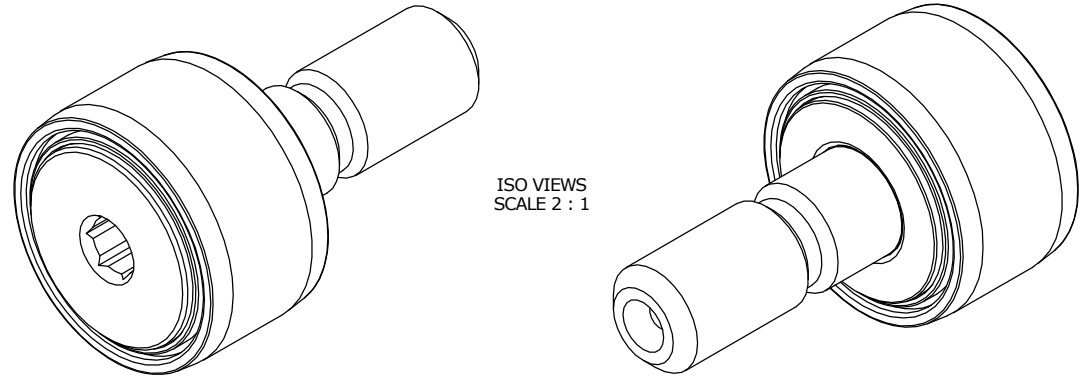

**MATERIAL NOTES:**

OUTER RACE - BEARING STEEL, HEAT TREATED  
 STUD - BEARING STEEL, ZONE HARDENED  
 NEEDLE ROLLER - BEARING STEEL, HEAT TREATED  
 WASHER - COLD ROLLED STEEL, HEAT TREATED  
 SEAL - SYNTHETIC

CUSTOMER PART#

XX = ± .01  
 XXX = ± .005  
 XXXX = ± .0005  
 ANGLES = ± 1'  
 INCH [METRIC]  
 FRACTION = ± 1/32

CARTER MANUFACTURING IS NOT RESPONSIBLE FOR TYPOGRAPHICAL ERRORS

**CARTER MANUFACTURING CO., INC.**  
 GRAND HAVEN, MICHIGAN 49417

**ENGINEERING CHANGE ORDER NOTE**

**REVISION**

PART NAME: ASSEMBLY

REVISION	AUTHOR BY	DRAWN BY	CHK'D BY	SALES	MATERIAL
E	HG	GJP	MD	KR	NOTED
REVISION BY	DATE	DATE	DATE	DATE	SHEET
SGW	10/2/2014	11/17/1999	9/30/2014	9/29/2014	1 OF 2