

LOAD RATINGS	
RATING	Lbs
RADIAL BASIC DYNAMIC [C]	10,880
STATIC THRUST LOAD	4,570
MAXIMUM STATIC CAPACITY [Co]	7,630

NOTES:

1. BEARING IS PACKED WITH NLGI GRADE 2, LITHIUM BASED GREASE UNLESS OTHERWISE SPECIFIED
2. ALL EXPOSED SURFACES HAVE BLACK OXIDE
3. CUSTOM LASER ETCHING AVAILABLE UPON REQUEST

MS NO.

NSN NO.

DRAWING NO.

FHRY-250-A

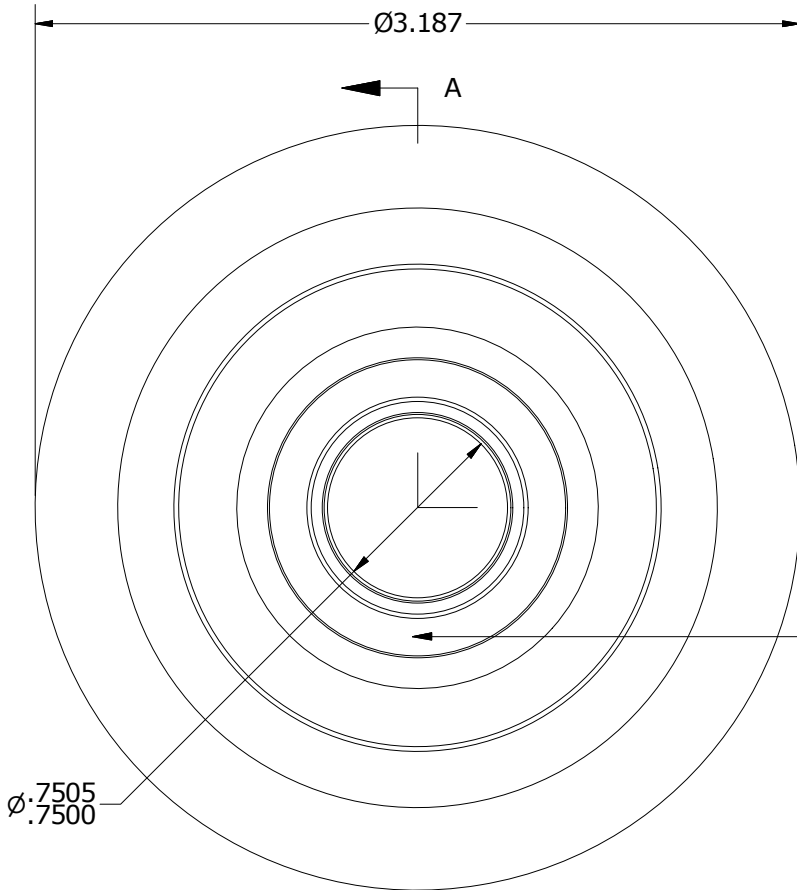

END VIEW
SCALE 1.25 : 1

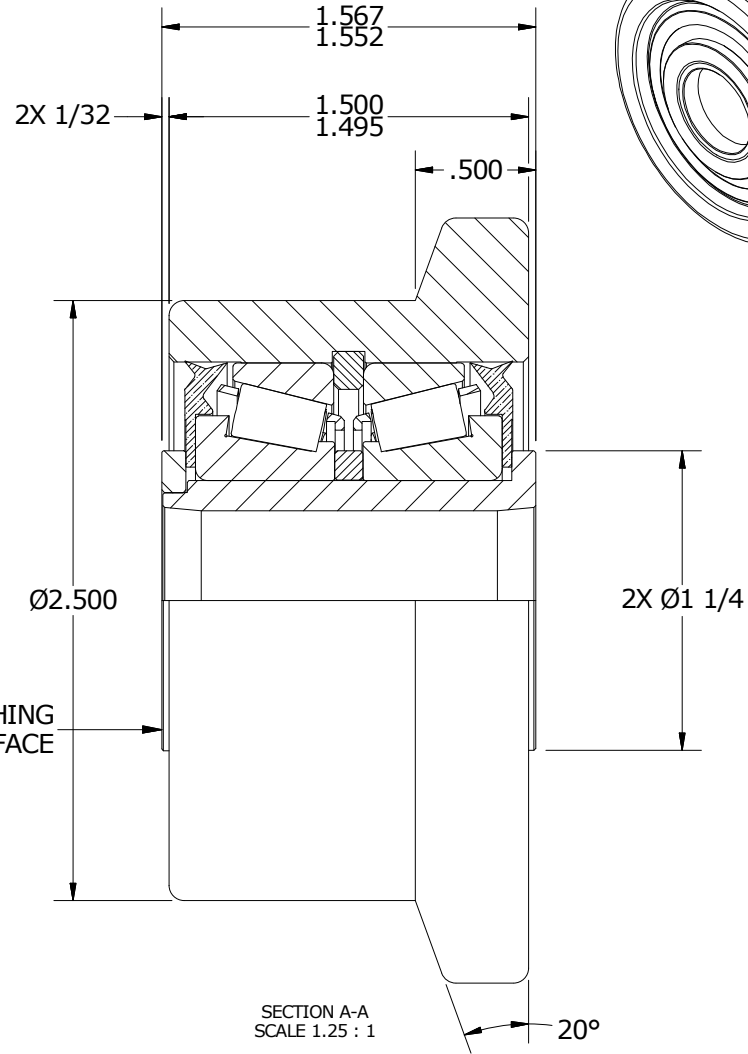

SECTION A-A
SCALE 1.25 : 1

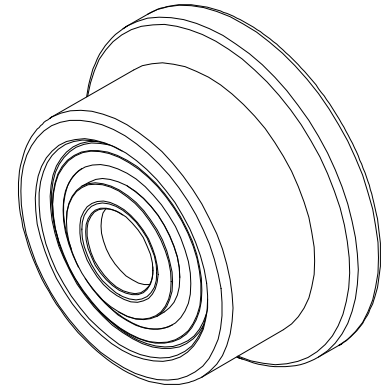

ISO VIEW
SCALE .625 : 1

MATERIAL NOTES:

OUTER ROLLER - BEARING STEEL, HEAT TREATED
YOKE - STEEL
WASHER - STEEL
TAPERED SET - L44600LA-902A7

CUSTOMER PART#

XX = ± .01
XXX = ± .005
XXXX = ± .0005
ANGLES = ± 1'
INCH [METRIC]
FRACTION = ± 1/32

CARTER MANUFACTURING IS NOT RESPONSIBLE FOR TYPOGRAPHICAL ERRORS

CARTER MANUFACTURING CO., INC.

GRAND HAVEN, MICHIGAN 49417

ENGINEERING CHANGE ORDER NOTE

REVISION

PART NAME: FHRY-250 ASSEMBLY

PRODUCT TYPE: FHRY

E

AUTHOR BY
HG

DRAWN BY
GJP

CHK'D BY
SGW

SALES
KPR

MATERIAL
NOTED

REVISION BY
MD

DATE
5/3/2019

DATE
1/4/2001

DATE
5/3/2019

DATE
1/3/2001

SHEET
1 OF 2