

NOTES:
1. BEARING IS PACKED WITH GREASE

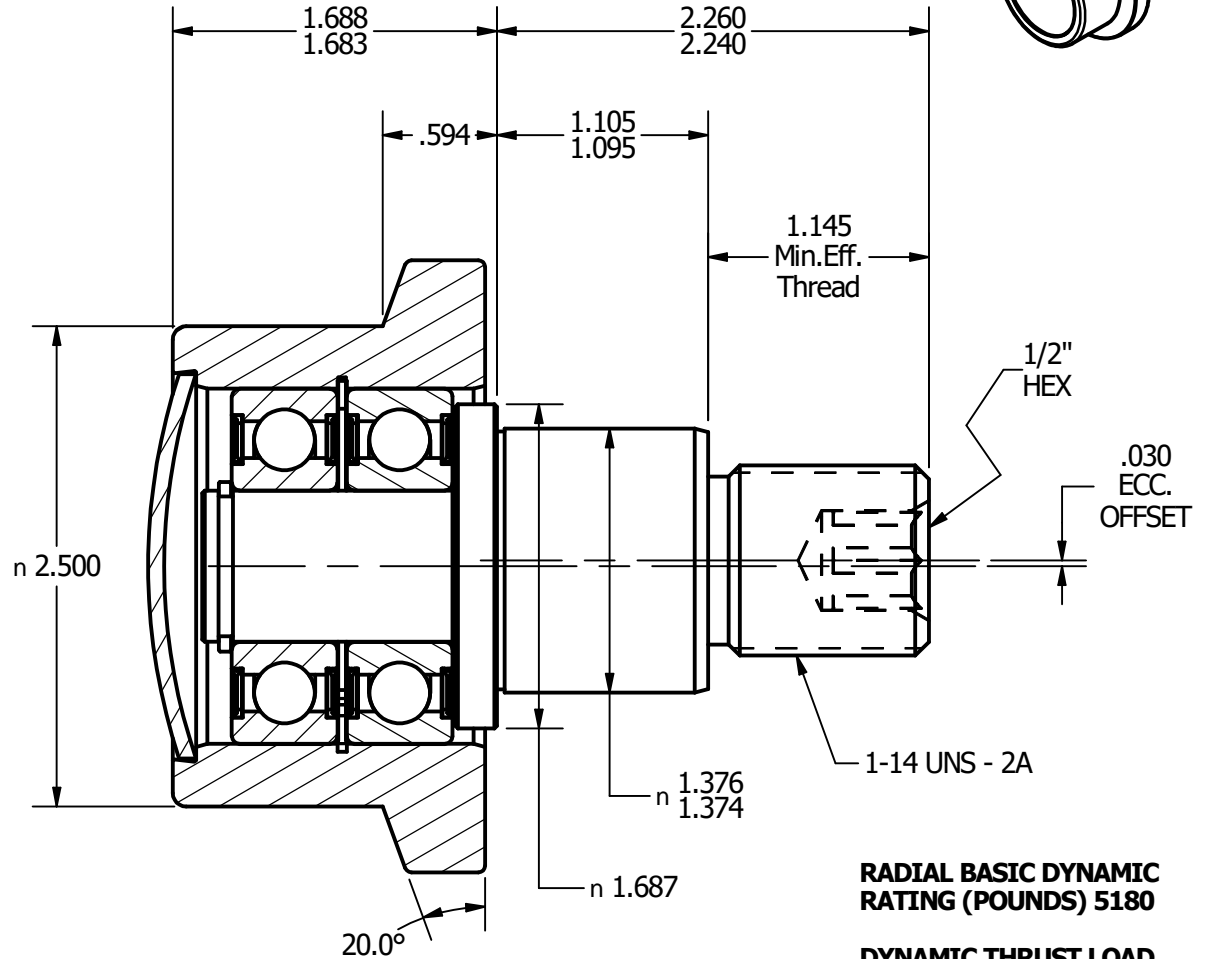
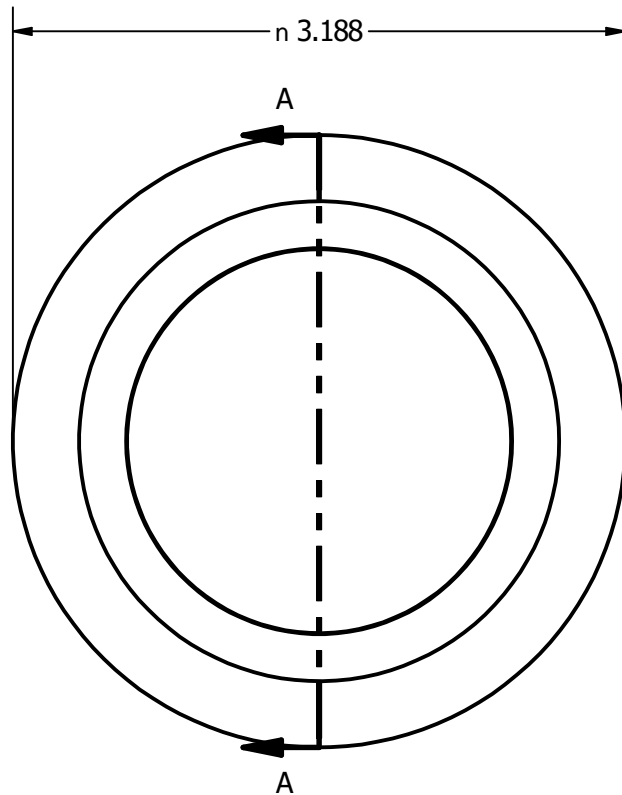
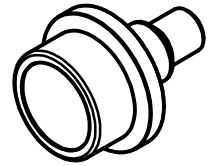

RADIAL BASIC DYNAMIC RATING (POUNDS) 5180

DYNAMIC THRUST LOAD RATING (POUNDS) 3185

MAXIMUM STATIC CAPACITY (POUNDS) 2270

SECTION A-A
 SCALE 1 : 1

MATERIAL NOTES:

OUTER - BEARING STEEL, HEAT TREATED
STUD - STRESSPROOF
BEARINGS - 6204.2RS
SNAP RINGS - SPRING STEEL
END CAP - COLD ROLLED STEEL

CUSTOMER PART#

.XX = .01
 .XXX = .005
 .XXXX = .0005
 ANGLES = 1°
 INCH [METRIC]

CHANGE NOTE:

CARTER MANUFACTURING IS NOT RESPONSIBLE FOR TYPOGRAPHICAL ERRORS

CARTER MANUFACTURING CO., INC.

GRAND HAVEN, MICHIGAN 49417

REVISION

PART NAME: **FHR-250 ASSEMBLY, ECCENTRIC**

SHEET 1 OF 2

A

AUTHOR. BY

DRAWN BY

CHK'D BY

SALES

MATERIAL

KR

JGV

KR

KPR

NOTED

REV. BY

DATE

DATE

DATE

DATE

DRAWING NO.

JGV

3/30/2006

3/29/2006

3/30/2006

3/30/2006

FHRE-250-A