

LOAD RATINGS	
RATING	Lbs
BASIC DYNAMIC	4,480
MAXIMUM STATIC	11,280

- NOTES:
 1. BEARING IS PACKED WITH LITHIUM BASED #2 WEIGHT GREASE
 2. ALL EXPOSED SURFACES HAVE BLACK OXIDE

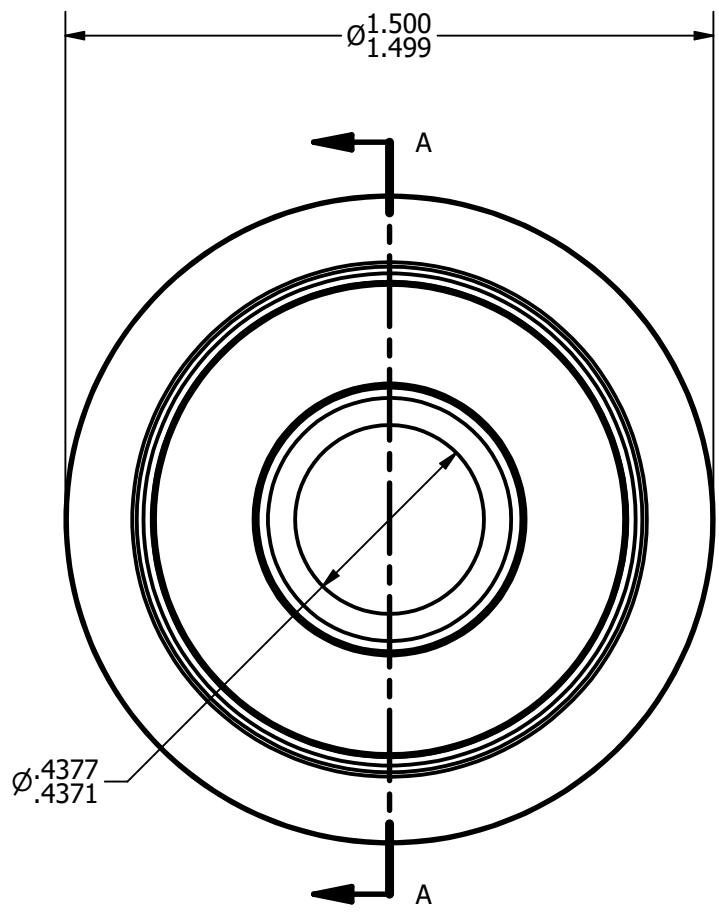

BASE VIEW
SCALE 2.25 : 1

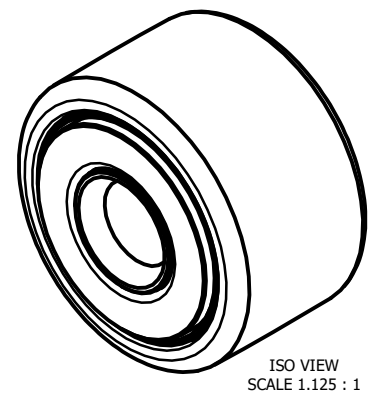
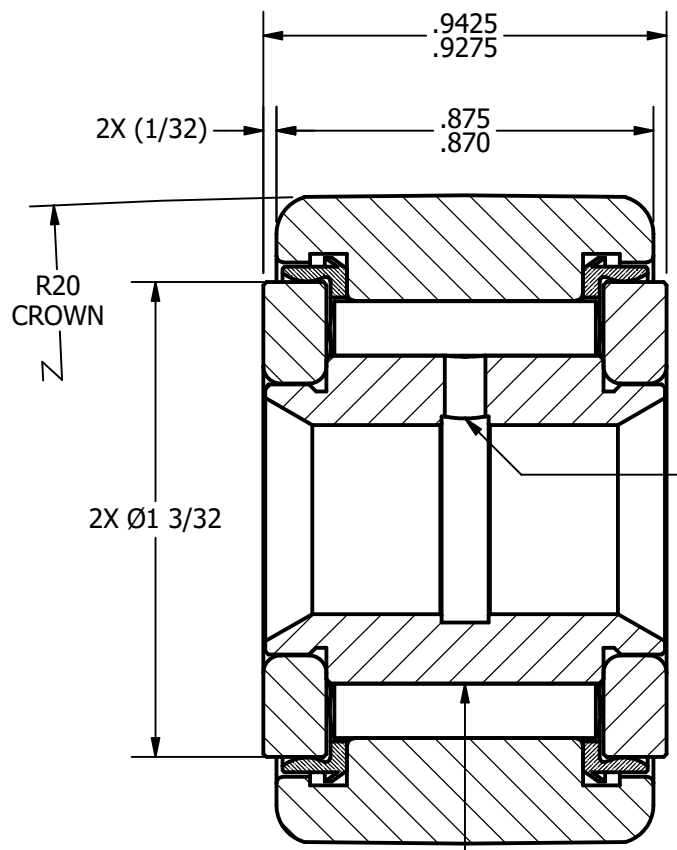

SECTION A-A
SCALE 2.25 : 1

MATERIAL NOTES:
 OUTER RACE - BEARING STEEL, HEAT TREATED
 INNER RACE - BEARING STEEL, ZONE HARDENED
 NEEDLE ROLLERS - BEARING STEEL, HEAT TREATED
 WASHERS - COLD ROLLED STEEL, HEAT TREATED
 SEALS - SYNTHETIC

CUSTOMER PART#	.XX = ± .01 .XXX = ± .005 .XXXX = ± .0005 ANGLES = ± 1' INCH [METRIC] FRACTION = ± 1/32
CHANGE NOTE:	

CARTER MANUFACTURING IS NOT RESPONSIBLE FOR TYPOGRAPHICAL ERRORS	
REVISION	
C	AUTHOR. BY
DB	JAF
REV. BY	DATE
MD	3/25/2013

CARTER MANUFACTURING CO., INC.					
GRAND HAVEN, MICHIGAN 49417					
PART NAME: ASSEMBLY			SHEET 1 OF 2		
SALES	MATERIAL	CHK'D BY	DATE	DATE	DRAWING NO.
KPR	NOTED	SGW	3/25/2013	8/4/2006	CYNB-48-S