

LOAD RATINGS		
RATING	lbf	Newtons
RADIAL BASIC DYNAMIC	3,930	17,481
MAXIMUM STATIC CAPACITY	8,500	37,808

- NOTES:
1. BEARING IS PACKED WITH NLGI GRADE 2, LITHIUM BASED GREASE (UNLESS OTHERWISE SPECIFIED)
 2. ALL EXPOSED STEEL SURFACES HAVE BLACK OXIDE
 3. LIMITING SPEED:
A. GREASE = 3,100 RPM

MS NO. _____ NSN NO. _____ DRAWING NO. _____

ISO VIEW
SCALE 1.375:1

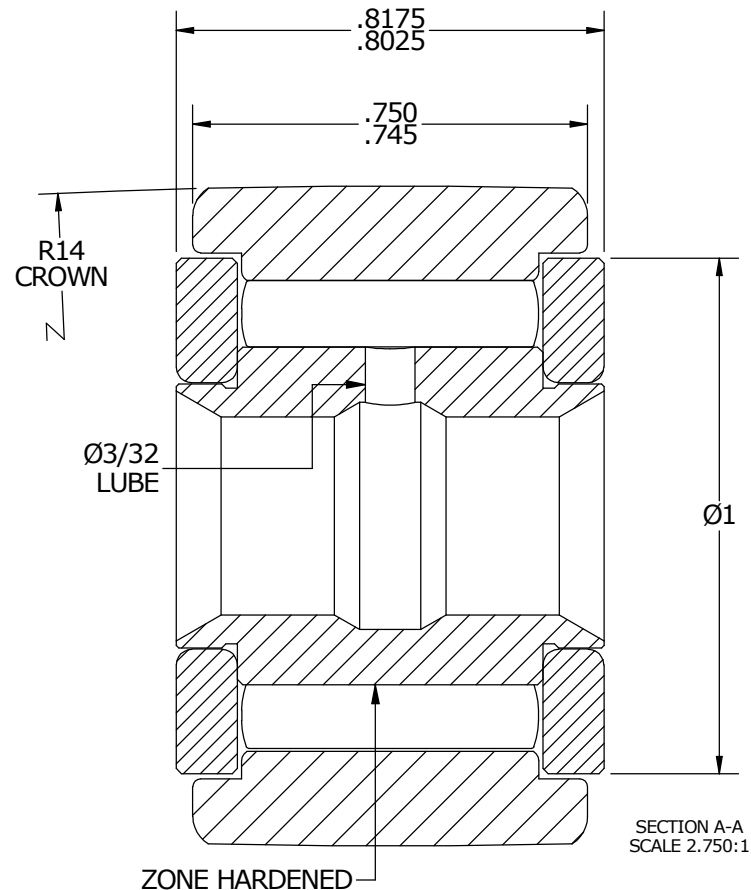
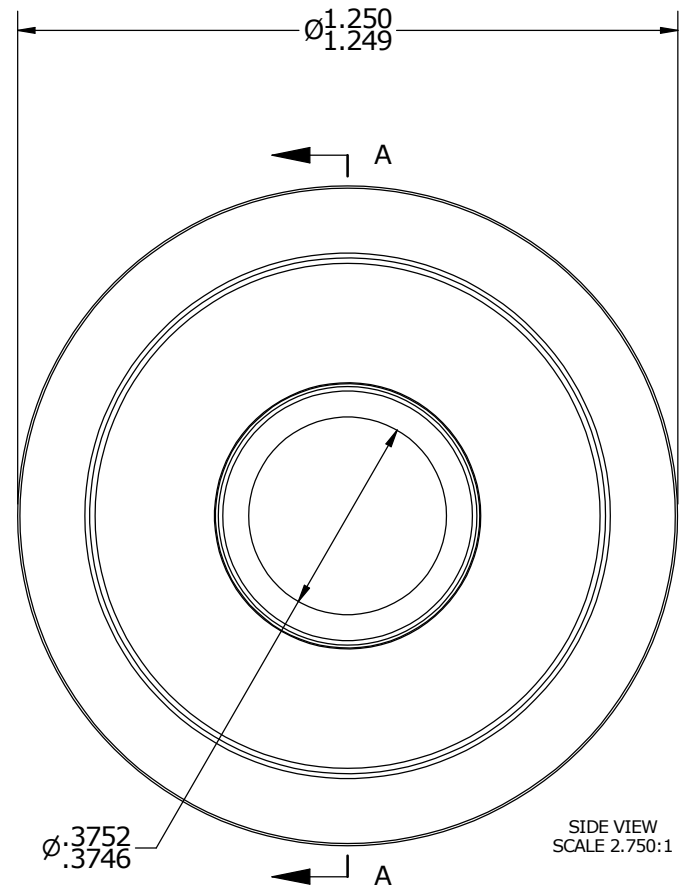
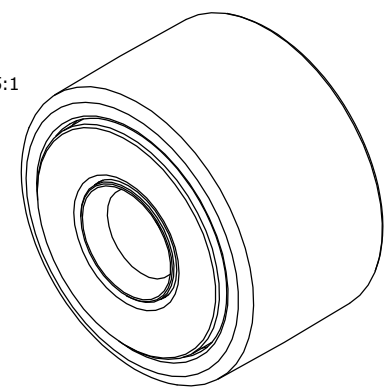

Recommended Shaft Fits		
Fit Type - Dimension	Ø (Inch)	Ø (mm)
Push - Max	.3747	9.5174
Push - Min	.3743	9.5072
Drive - Max	.3753	9.5326
Drive - Min	.3749	9.5225
Press - Max	.3755	9.5377
Press - Min	.3751	9.5275

MATERIAL NOTES:

OUTER RACE - BEARING STEEL, HEAT TREATED
 INNER RACE - BEARING STEEL, ZONE HARDENED
 NEEDLE ROLLER - BEARING STEEL, HEAT TREATED
 WASHER - BEARING STEEL, HEAT TREATED*

*MAY BE CONSTRUCTED OF COLD ROLLED STEEL DEPENDING ON MATERIAL AVAILABILITY

CUSTOMER PART#	XX = ± .01 XXX = ± .005 XXXX = ± .0005 ANGLES = ± 1' INCH [METRIC] FRACTION = ± 1/32
ENGINEERING CHANGE ORDER NOTE	

CARTER MANUFACTURING IS NOT RESPONSIBLE FOR TYPOGRAPHICAL ERRORS

REVISION	
B	AUTHOR BY HG
REVISION BY SGW	DATE 6/7/2016

CARTER MANUFACTURING CO., INC.
 GRAND HAVEN, MICHIGAN 49417

PART NAME: ASSEMBLY

DRAWN BY	CHK'D BY	SALES	MATERIAL
SGW	MD	KR	NOTED
DATE	DATE	DATE	SHEET
7/19/2007	6/2/2016	6/13/2016	1 OF 2