

LOAD RATINGS		
RATING	lbf	Newtons
RADIAL BASIC DYNAMIC	1,660	7,384
MAXIMUM STATIC CAPACITY	4,130	18,371

- NOTES:
1. BEARING IS PACKED WITH NLGI GRADE 2, LITHIUM BASED GREASE (UNLESS OTHERWISE SPECIFIED)
 2. ALL EXPOSED STEEL SURFACES HAVE BLACK OXIDE
 3. LIMITING SPEED:
A. GREASE = 6,400 RPM

MS NO. _____ NSN NO. _____ DRAWING NO. CYNB-24-S

ISO VIEW
SCALE 2.250 : 1

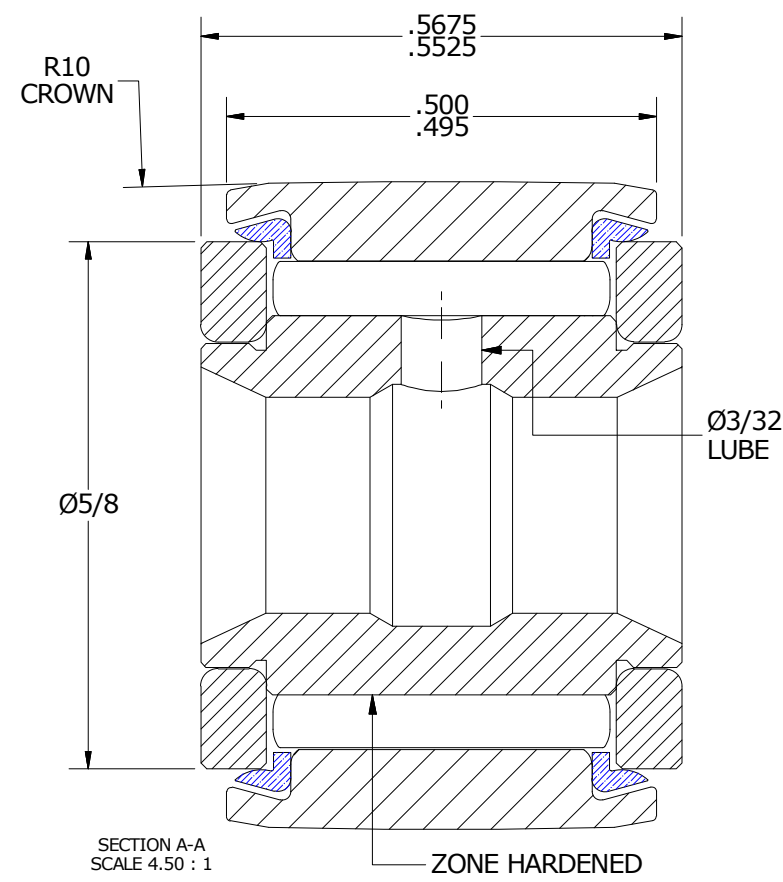
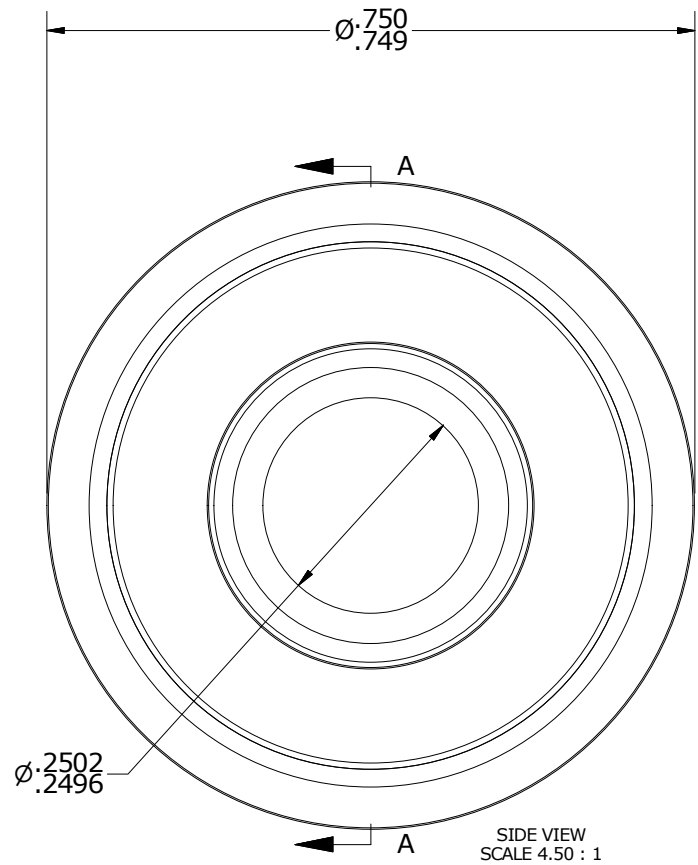
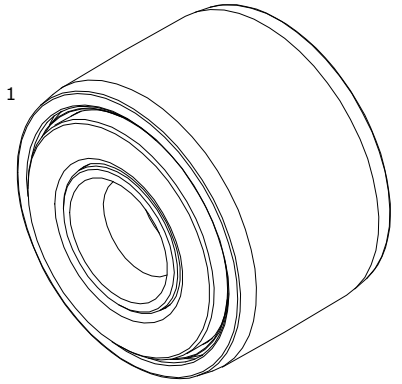

Recommended Shaft Fits		
Fit Type - Dimension	Ø (Inch)	Ø (mm)
Push - Max	.2497	6.3424
Push - Min	.2493	6.3322
Drive - Max	.2503	6.3576
Drive - Min	.2499	6.3475
Press - Max	.2505	6.3627
Press - Min	.2501	6.3525

MATERIAL NOTES:

OUTER RING - BEARING STEEL, HEAT TREATED
 INNER RING - BEARING STEEL, ZONE HARDENED
 NEEDLE ROLLER(S) - BEARING STEEL, HEAT TREATED
 WASHER(S) - BEARING STEEL, HEAT TREATED
 SEAL(S) - SYNTHETIC

CUSTOMER PART#	XX = ± .01 XXX = ± .005 XXXX = ± .0005 ANGLES = ± 1' INCH [METRIC] FRACTION = ± 1/32
ENGINEERING CHANGE ORDER NOTE	

CARTER MANUFACTURING IS NOT RESPONSIBLE FOR TYPOGRAPHICAL ERRORS	
REVISION	
B	AUTHOR BY HG
REVISION BY SGW	DATE 4/27/2017

CARTER MANUFACTURING CO., INC. GRAND HAVEN, MICHIGAN 49417					
PART NAME: ASSEMBLY					
DRAWN BY GJP	CHK'D BY MD	SALES KR	MATERIAL NOTED		
DATE 7/18/2001	DATE 4/27/2017	DATE 4/27/2017	DATE 4/27/2017	SHEET 1 OF 2	