

LOAD RATINGS		
RATING	lbf	Newtons
RADIAL BASIC DYNAMIC	3,144	13,985
MAXIMUM STATIC CAPACITY	6,800	30,248

NOTES:
 1. BEARING IS PACKED WITH NLGI GRADE 2, FOOD GRADE, H1 GREASE (UNLESS OTHERWISE SPECIFIED)
 2. LIMITING SPEED:
 A. GREASE = 3,100 RPM

MS NO. _____ NSN NO. _____ DRAWING NO. CSY-44-S

ISO VIEW
SCALE 1.375:1

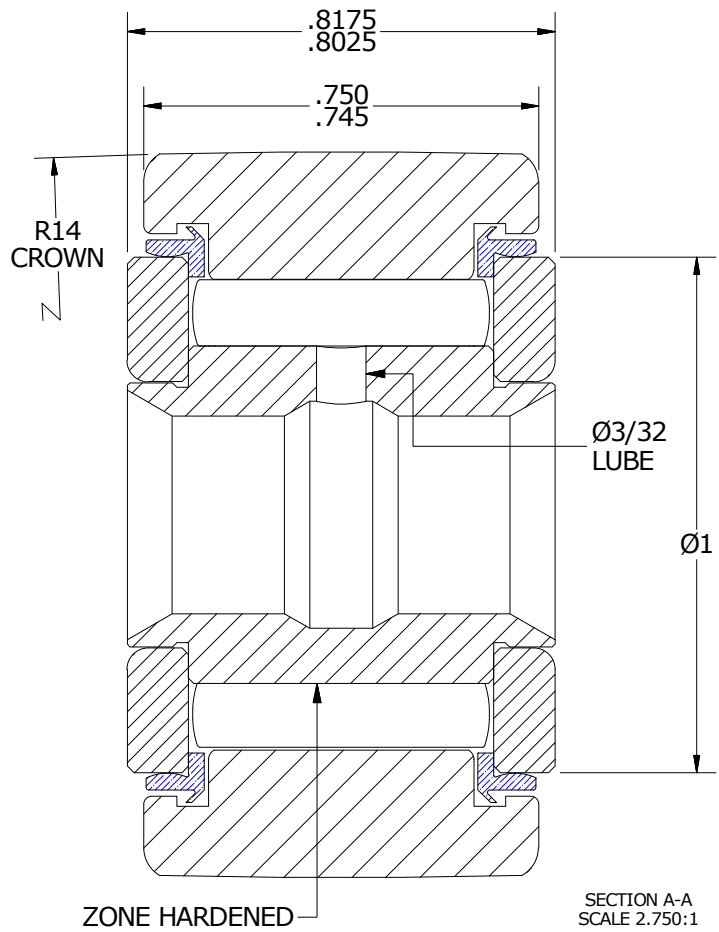
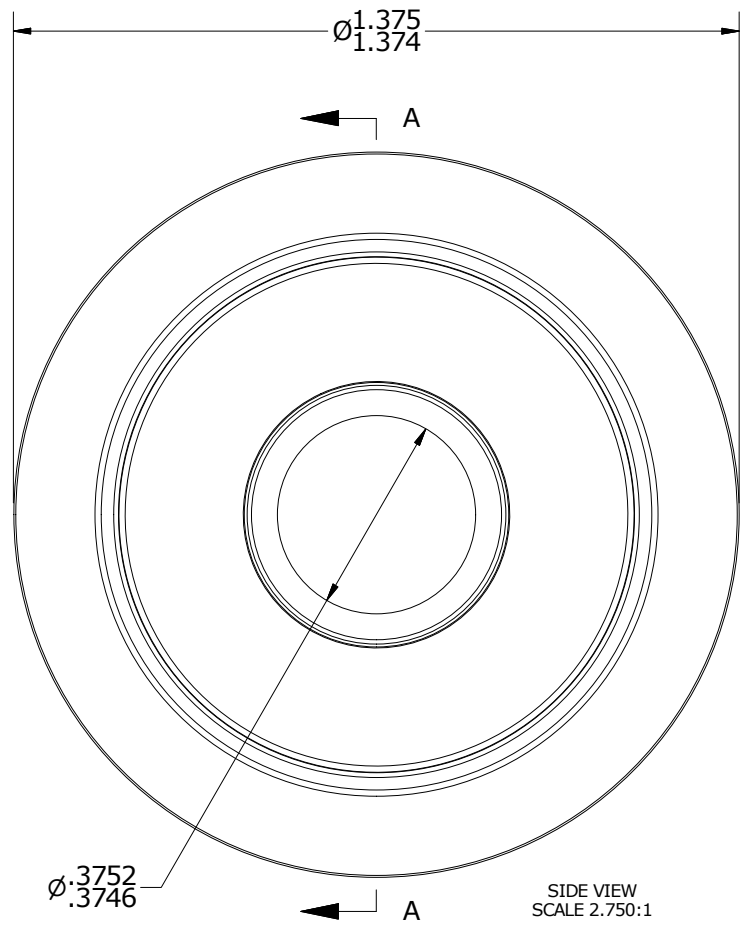
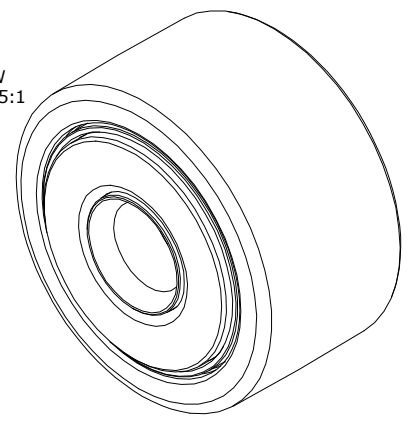

Recommended Shaft Fits		
Fit Type - Dimension	Ø (Inch)	Ø (mm)
Push - Max	.3747	9.5174
Push - Min	.3743	9.5072
Drive - Max	.3753	9.5326
Drive - Min	.3749	9.5225
Press - Max	.3755	9.5377
Press - Min	.3751	9.5275

MATERIAL NOTES:
 OUTER RING - 440C STAINLESS STEEL, HEAT TREATED
 INNER RING - 440C STAINLESS STEEL, ZONE HARDENED
 NEEDLE ROLLER(S) - 440C STAINLESS STEEL, HEAT TREATED
 WASHER(S) - 440C STAINLESS STEEL, HEAT TREATED
 SEAL(S) - SYNTHETIC

CUSTOMER PART# _____
 XX = ± .01
 XXX = ± .005
 XXXX = ± .0005
 ANGLES = ± 1'
 INCH [METRIC]
 FRACTION = ± 1/32

ENGINEERING CHANGE ORDER NOTE

CARTER MANUFACTURING IS NOT RESPONSIBLE FOR TYPOGRAPHICAL ERRORS

CARTER MANUFACTURING CO., INC.
 GRAND HAVEN, MICHIGAN 49417

REVISION		PART NAME: ASSEMBLY					
B	AUTHOR BY HG	DRAWN BY JGV	CHK'D BY MD	SALES KR	MATERIAL NOTED		
REVISION BY SGW	DATE 6/30/2016	DATE 2/24/2004	DATE 6/14/2016	DATE 7/15/2016	SHEET 1 OF 2		