

NOTES:

1. BUSHING IS IMPREGNATED WITH OIL
2. ALL EXPOSED SURFACES HAVE BLACK OXIDE

MS NO.

NSN NO.

DRAWING NO.

CSFHE-56-A

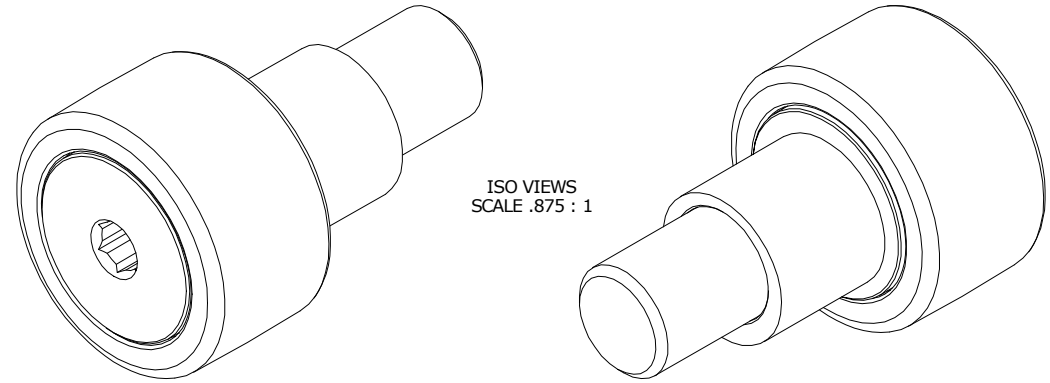

ISO VIEWS
SCALE .875 : 1

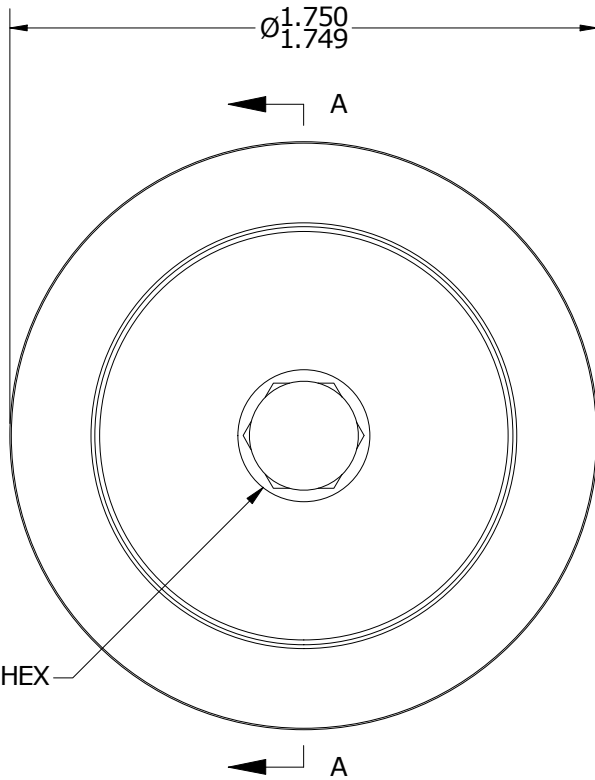

END VIEW
SCALE 1.75 : 1

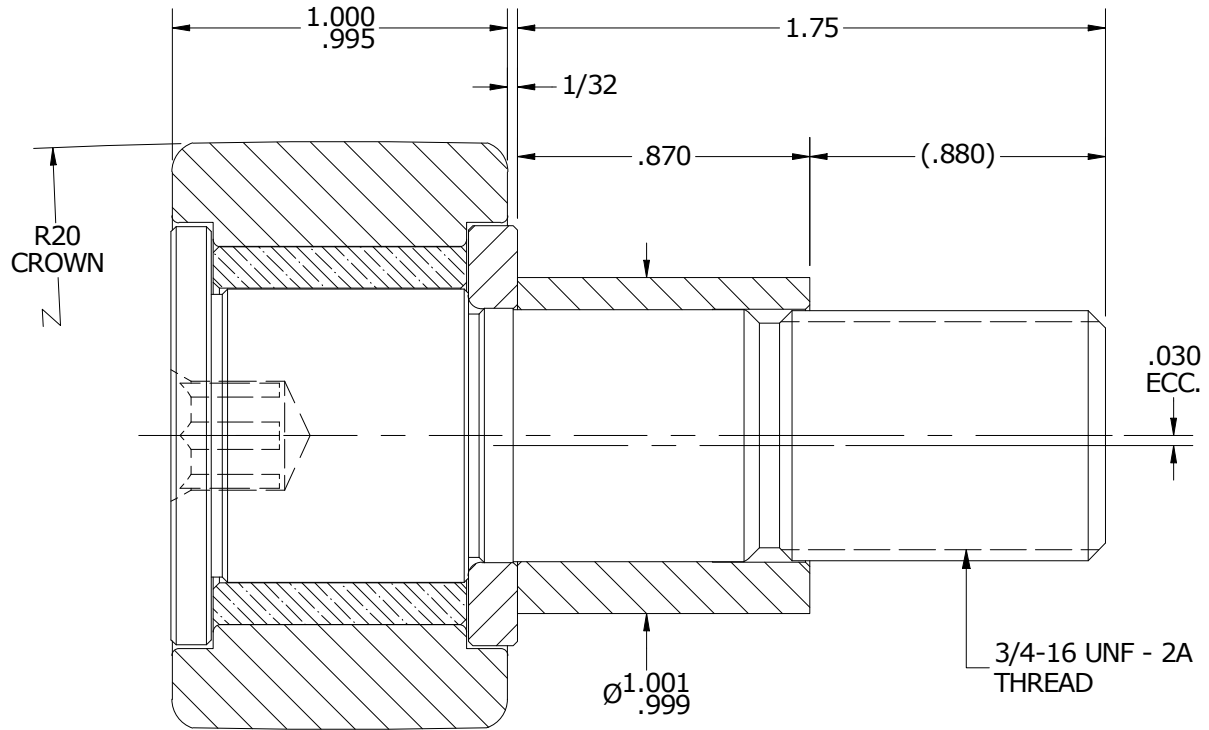

SECTION A-A
SCALE 1.75 : 1

MATERIAL NOTES:

- OUTER RING - BEARING STEEL, HEAT TREATED
- STUD - COLD ROLLED STEEL
- WASHER - BEARING STEEL, HEAT TREATED
- BUSHING - SINTERED BRONZE
- ECCENTRIC SLEEVE - COLD ROLLED STEEL

CUSTOMER PART#

XX = ± .01
XXX = ± .005
XXXX = ± .0005
ANGLES = ± 1'
INCH [METRIC]
FRACTION = ± 1/32

CARTER MANUFACTURING IS
NOT RESPONSIBLE FOR
TYPOGRAPHICAL ERRORS

CARTER MANUFACTURING CO., INC.

GRAND HAVEN, MICHIGAN 49417

ENGINEERING CHANGE ORDER NOTE

REVISION

PART NAME: ASSEMBLY

PRODUCT TYPE: SFH

B

AUTHOR BY
HG

DRAWN BY
MD

CHK'D BY
SGW

SALES
NC

MATERIAL
NOTED

REVISION BY
MD

DATE
10/2/2019

DATE
8/25/2017

DATE
10/2/2019

DATE
8/25/2017

SHEET
1 OF 2