

NOTES:

1. BUSHING IS IMPREGNATED WITH OIL
2. ALL EXPOSED STEEL SURFACES HAVE BLACK OXIDE

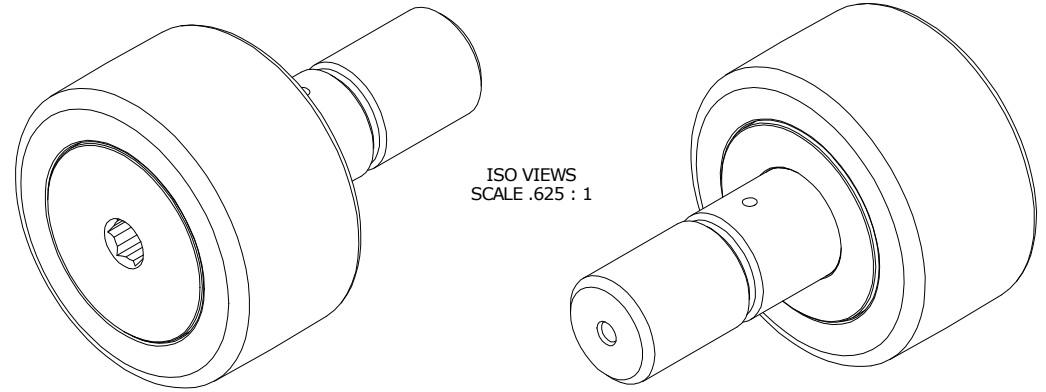

ISO VIEWS
SCALE .625 : 1

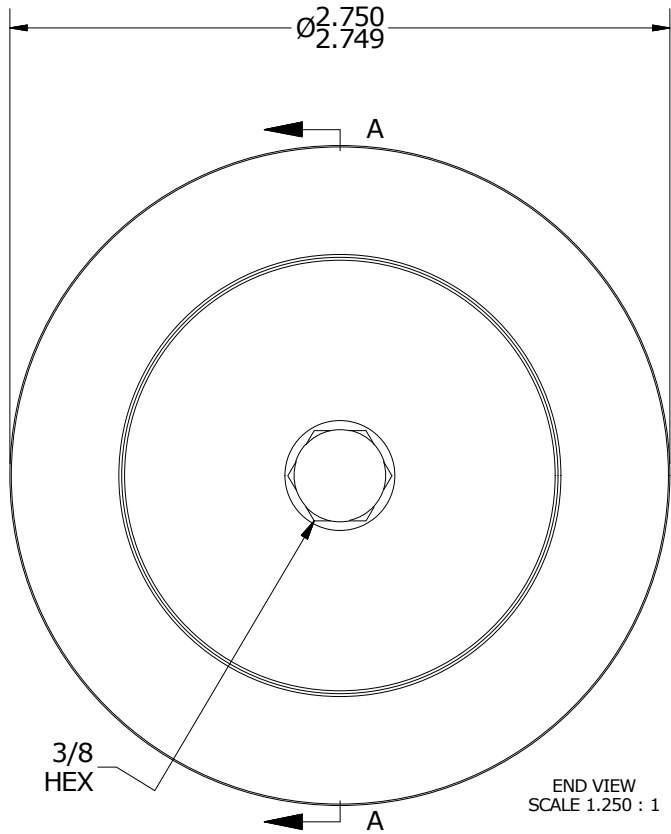

END VIEW
SCALE 1.250 : 1

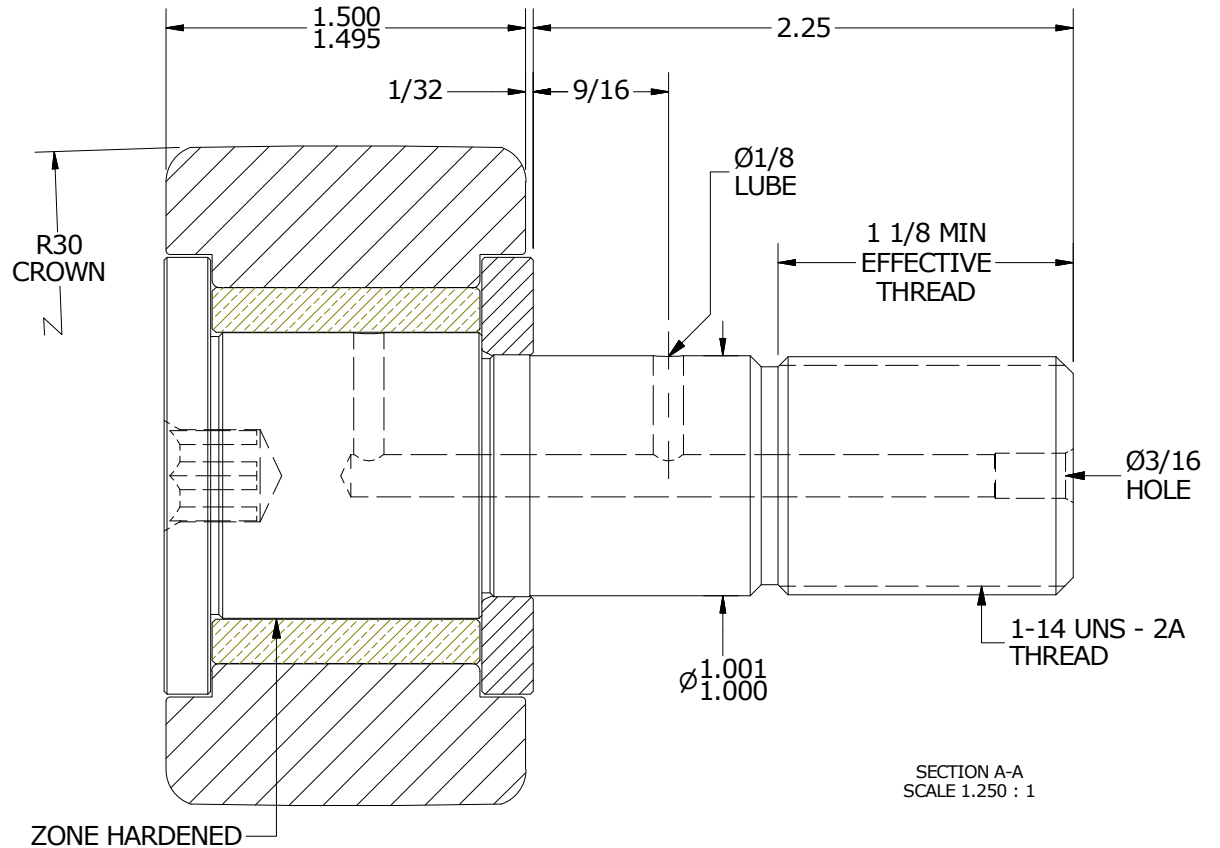

SECTION A-A
SCALE 1.250 : 1

MATERIAL NOTES:

OUTER RING - BEARING STEEL, HEAT TREATED
 STUD - BEARING STEEL, ZONE HARDENED
 BUSHING - SINTERED BRONZE
 WASHER - COLD ROLLED STEEL, HEAT TREATED

CUSTOMER PART#

XX = ± .01
 XXX = ± .005
 XXXX = ± .0005
 ANGLES = ± 1'
 INCH [METRIC]
 FRACTION = ± 1/32

CARTER MANUFACTURING IS
 NOT RESPONSIBLE FOR
 TYPOGRAPHICAL ERRORS

CARTER MANUFACTURING CO., INC.

GRAND HAVEN, MICHIGAN 49417

ENGINEERING CHANGE ORDER NOTE

REVISION

PART NAME: ASSEMBLY

A

AUTHOR BY
HG

DRAWN BY
SGW

CHK'D BY
MD

SALES
KR

MATERIAL
NOTED

REVISION BY
SGW

DATE
1/2/2017

DATE
12/20/2016

DATE
12/20/2016

DATE
12/20/2016

SHEET
1 OF 2