

NOTES:

1. BUSHING IS IMPREGNATED WITH OIL
2. ALL EXPOSED SURFACES HAVE BLACK OXIDE

MS NO.

NSN NO.

DRAWING NO.

CSFH-40-A

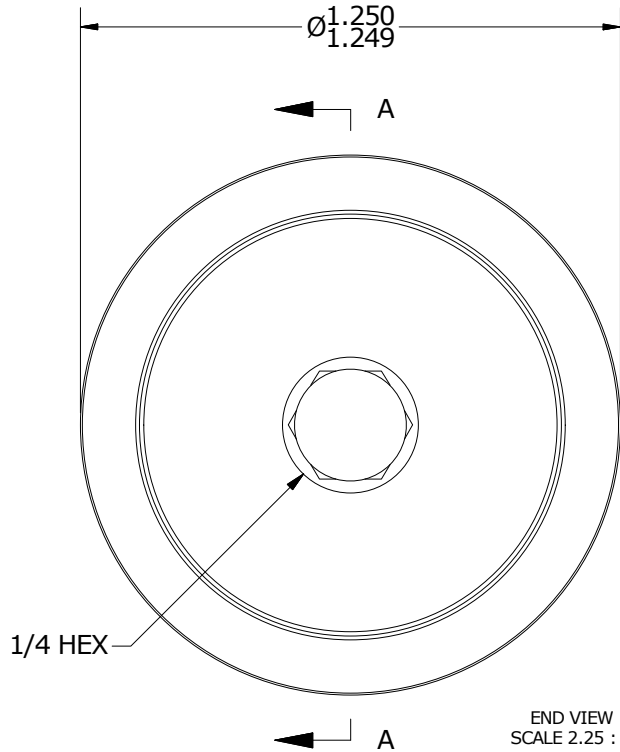
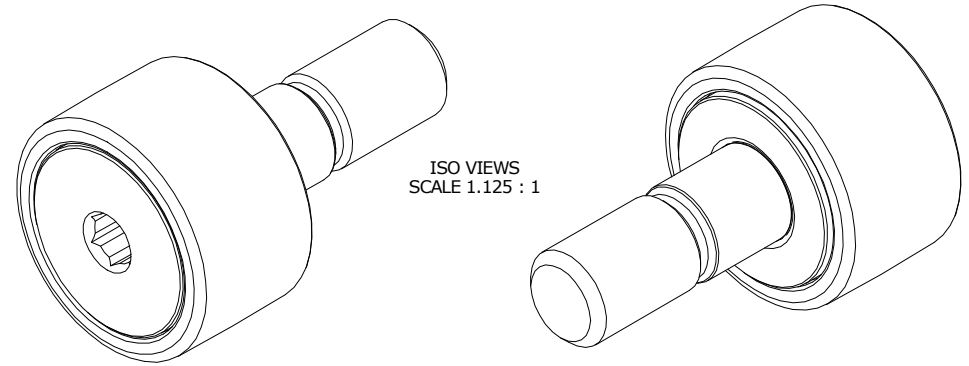

END VIEW
SCALE 2.25 : 1

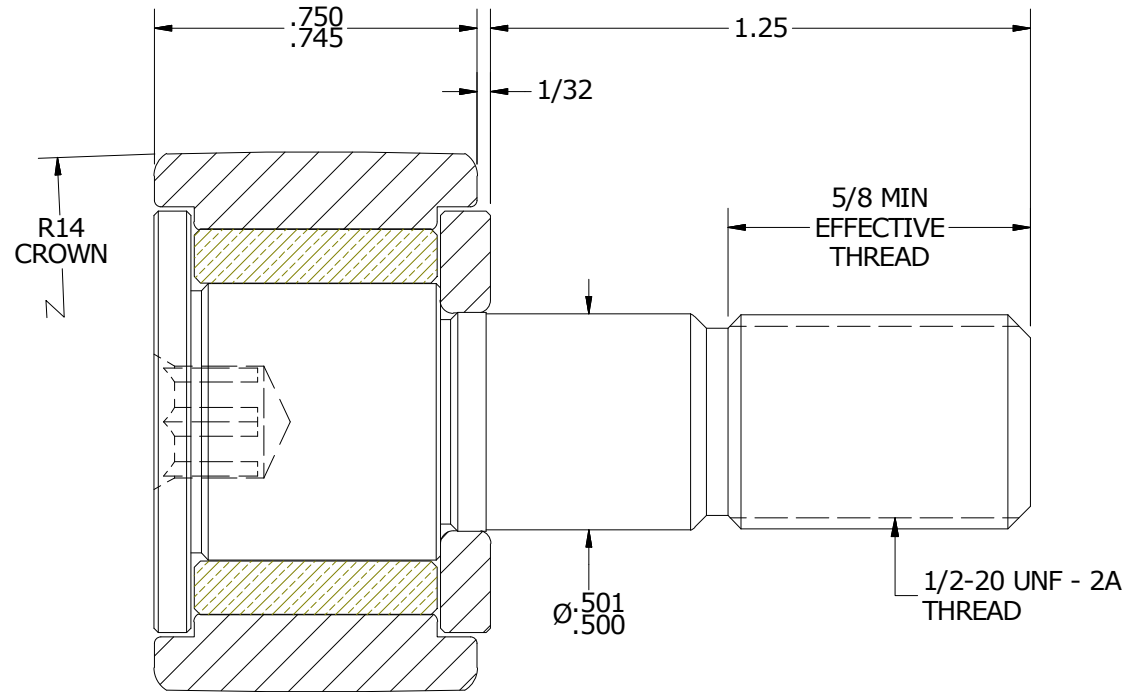

SECTION A-A
SCALE 2.25 : 1

MATERIAL NOTES:

OUTER RING - BEARING STEEL, HEAT TREATED
 STUD - COLD ROLLED STEEL
 WASHER - BEARING STEEL, HEAT TREATED
 BUSHING - SINTERED BRONZE

CUSTOMER PART#

XX = ± .01
 XXX = ± .005
 XXXX = ± .0005
 ANGLES = ± 1'
 INCH [METRIC]
 FRACTION = ± 1/32

CARTER MANUFACTURING IS
 NOT RESPONSIBLE FOR
 TYPOGRAPHICAL ERRORS

CARTER MANUFACTURING CO., INC.

GRAND HAVEN, MICHIGAN 49417

REVISION

PART NAME: ASSEMBLY

ENGINEERING CHANGE ORDER NOTE

B

AUTHOR BY
HG

DRAWN BY
MDS

CHK'D BY
MD

SALES
KR

MATERIAL
NOTED

REVISION BY
SGW

DATE
2/23/2017

DATE
6/13/2000

DATE
2/16/2017

DATE
2/23/2017

SHEET
1 OF 2