

LOAD RATINGS		
RATING	lbf	Newtons
RADIAL BASIC DYNAMIC	6,472	28,789
MAXIMUM STATIC CAPACITY	14,798	65,824

RECOMMENDED MOUNTING HOLE Ø		
Limit	Inch	mm
MIN	1.1250	28.5750
MAX	1.1255	28.5877

- NOTES:
- BEARING IS PACKED WITH NLGI GRADE 2, FOOD GRADE H1 GREASE (UNLESS OTHERWISE SPECIFIED)
 - LIMITING SPEED:
A. GREASE = 1,400

MAXIMUM CLAMPING TORQUE		
Thread Type	Inch Lbs	Nm
DRY	1,500	169.5
LUBRICATED	750	84.7

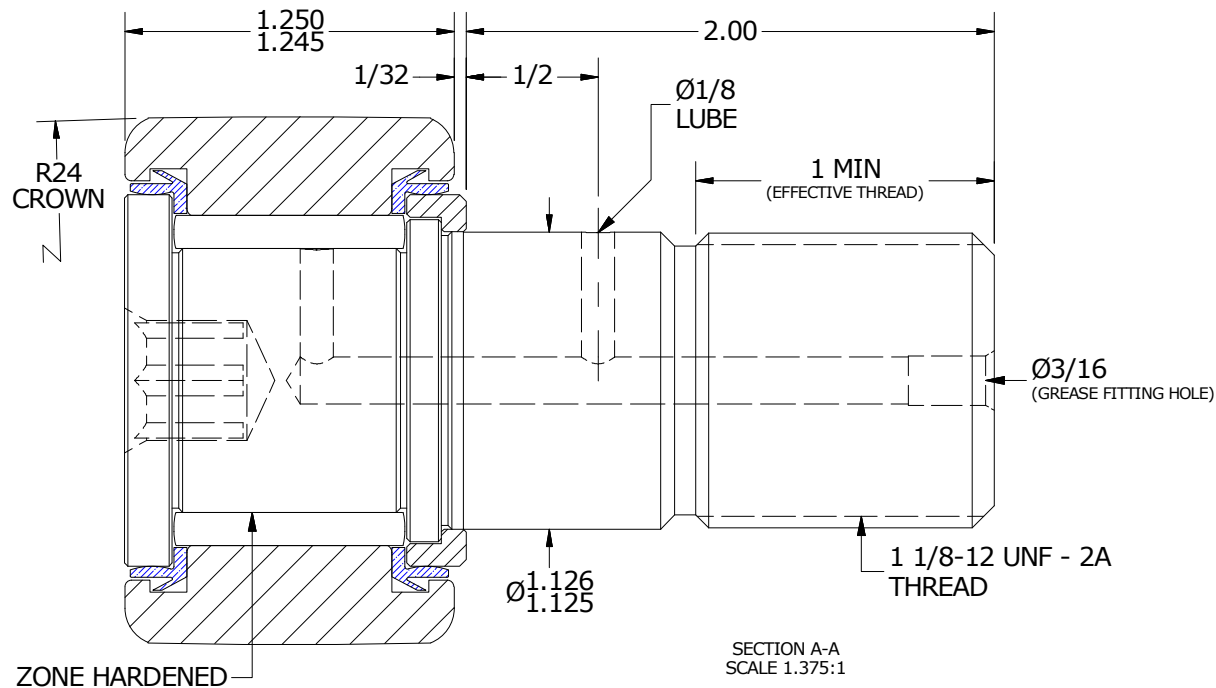
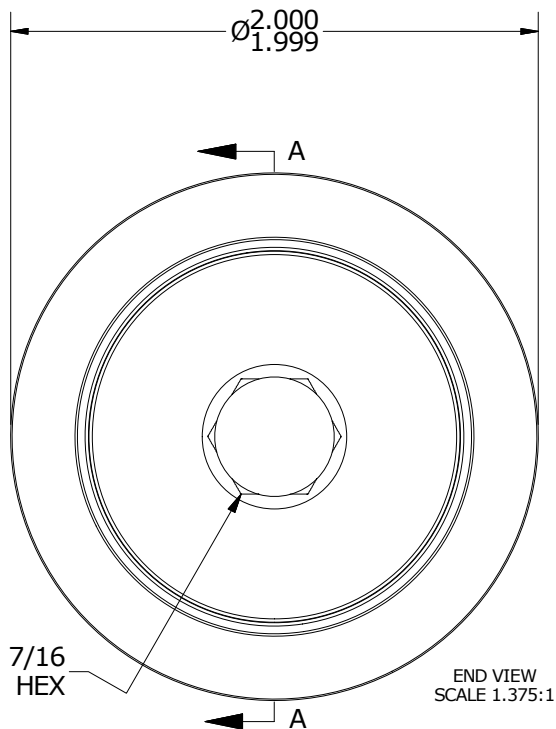
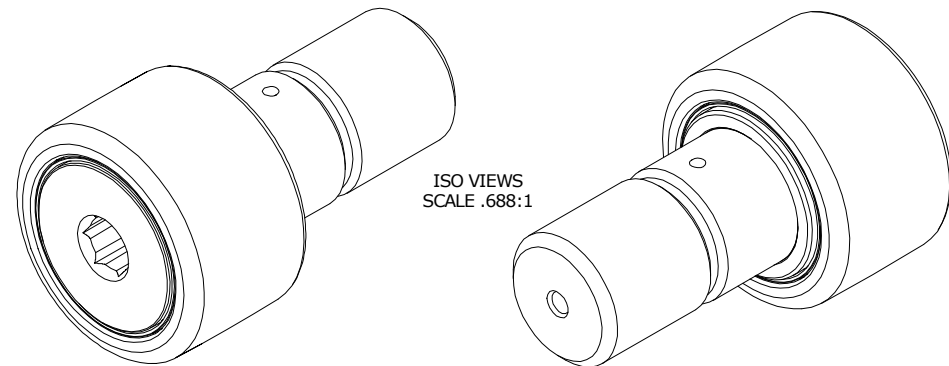

MATERIAL NOTES:

OUTER RING - 440C STAINLESS, HEAT TREATED
 STUD - 440C STAINLESS, ZONE HARDENED
 NEEDLE ROLLER(S) - 440C STAINLESS, HEAT TREATED
 WASHER - 440C STAINLESS, HEAT TREATED
 SEAL(S) - SYNTHETIC

CUSTOMER PART#

XX = ± .01
 XXX = ± .005
 XXXX = ± .0005
 ANGLES = ± 1'
 INCH [METRIC]
 FRACTION = ± 1/32

CARTER MANUFACTURING IS NOT RESPONSIBLE FOR TYPOGRAPHICAL ERRORS

CARTER MANUFACTURING CO., INC.

GRAND HAVEN, MICHIGAN 49417

ENGINEERING CHANGE ORDER NOTE

REVISION

PART NAME: ASSEMBLY

PRODUCT TYPE: CNB / SC

B

AUTHOR BY
HG

DRAWN BY
JAF

CHK'D BY
MD

SALES
KR

MATERIAL
NOTED

REVISION BY
JLB

DATE
8/9/2018

DATE
7/25/2006

DATE
8/9/2018

DATE
8/8/2018

SHEET
1 OF 2