

RECOMMENDED MOUNTING HOLE Ø		
Limit	Inch	mm
MIN	.8750	22.2250
MAX	.8755	22.2377

MAXIMUM CLAMPING TORQUE**		
Thread Type	Inch Lbs	Nm
LUBRICATED	750	84.7

- NOTES:
- BEARING IS PACKED WITH NLGI GRADE 2, LITHIUM BASED GREASE UNLESS OTHERWISE SPECIFIED
 - URETHANE SPECIFICATIONS:
 - DUROMETER = 80 SHORE A
 - COLOR = BLUE
 - ALL EXPOSED STEEL SURFACES HAVE BLACK OXIDE
 - CUSTOM LASER ETCHING AVAILABLE UPON REQUEST

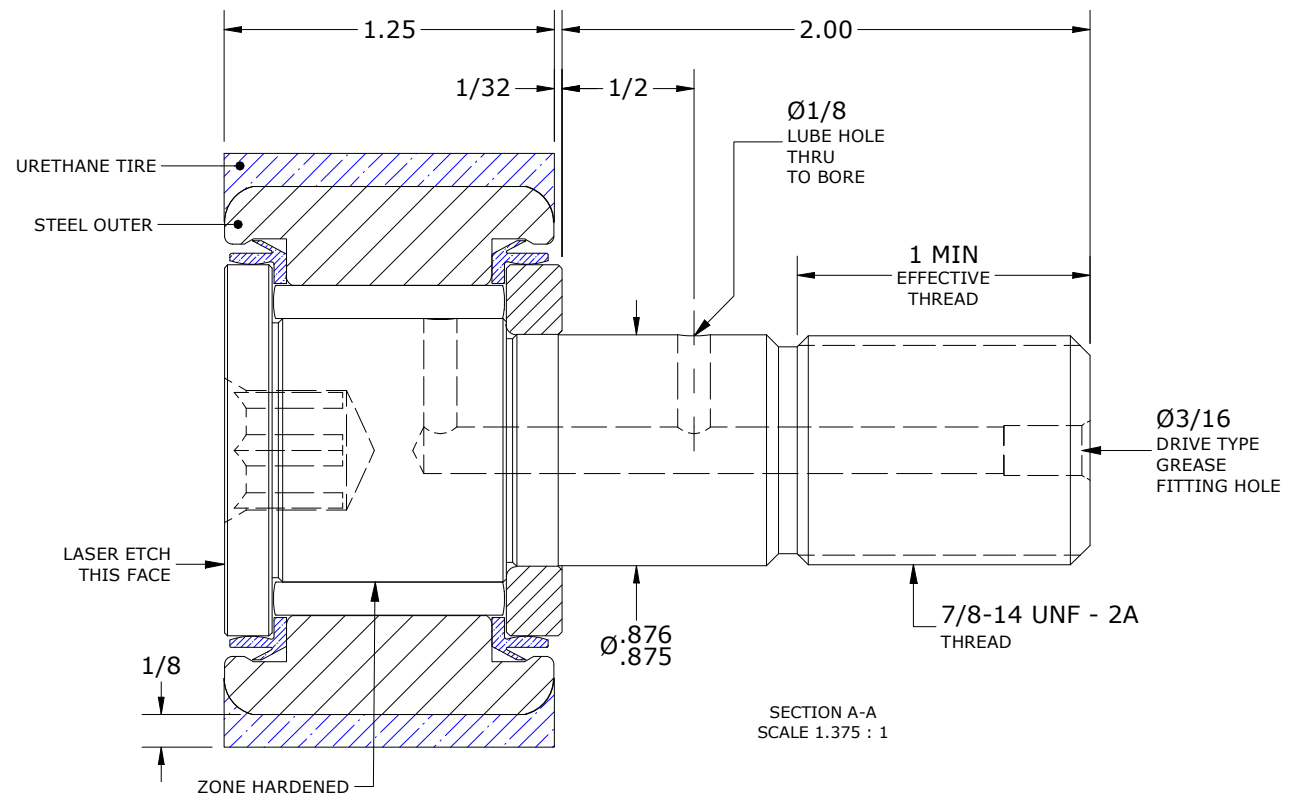
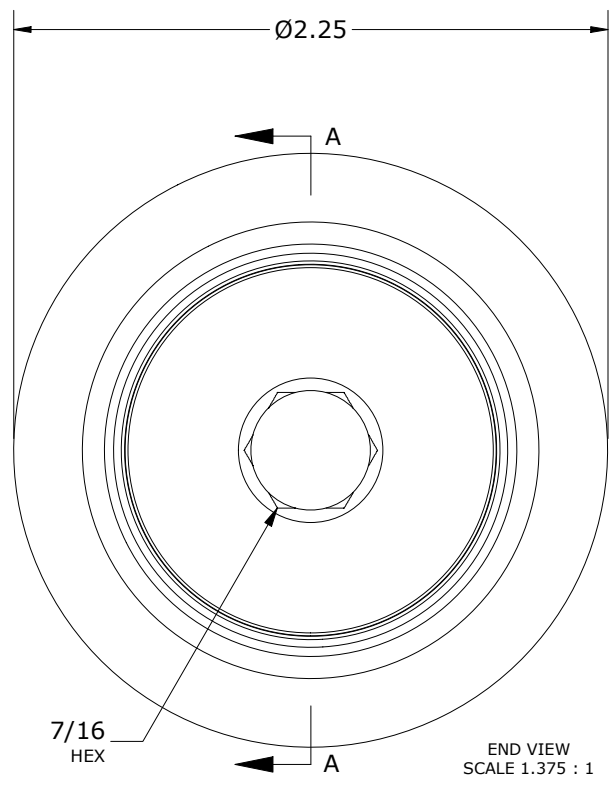
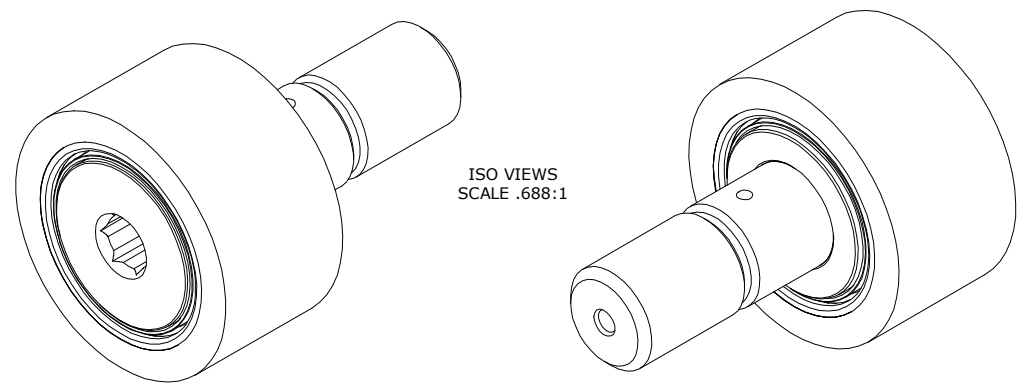

**TORQUE SPECIFICATION IS BASED ON LUBRICATED THREADS, IF USING DRY THREADS DOUBLE TORQUE VALUE

MATERIAL NOTES:

OUTER RING - BEARING STEEL, HEAT TREATED
 TIRE - URETHANE
 STUD - BEARING STEEL, ZONE HARDENED
 NEEDLE ROLLER(S) - BEARING STEEL, HEAT TREATED
 WASHER - BEARING STEEL, HEAT TREATED
 SEAL(S) - SYNTHETIC

<i>CUSTOMER PART#</i>	XX = ± .01 XXX = ± .005 XXXX = ± .0005 ANGLES = ± 1' INCH [METRIC] FRACTION = ± 1/32
<i>ENGINEERING CHANGE ORDER NOTE</i>	

CARTER MANUFACTURING IS NOT RESPONSIBLE FOR TYPOGRAPHICAL ERRORS				CARTER MANUFACTURING CO., INC. GRAND HAVEN, MICHIGAN 49417			
<i>REVISION</i>				PART NAME: ASSEMBLY		PRODUCT TYPE: CRT	
C	AUTHOR BY HG	DRAWN BY SGW	CHK'D BY MD	SALES KR	MATERIAL NOTED		
REVISION BY SGW	DATE 7/20/2020	DATE 10/9/2007	DATE 7/20/2020	DATE 7/20/2018	SHEET 1 OF 2		