

NOTES:

1. BUSHING IS IMPREGNATED WITH OIL
2. ALL EXPOSED STEEL SURFACES HAVE BLACK OXIDE

MS NO.

NSN NO.

DRAWING NO.

CNYR-96

ISO VIEW
SCALE .593 : 1

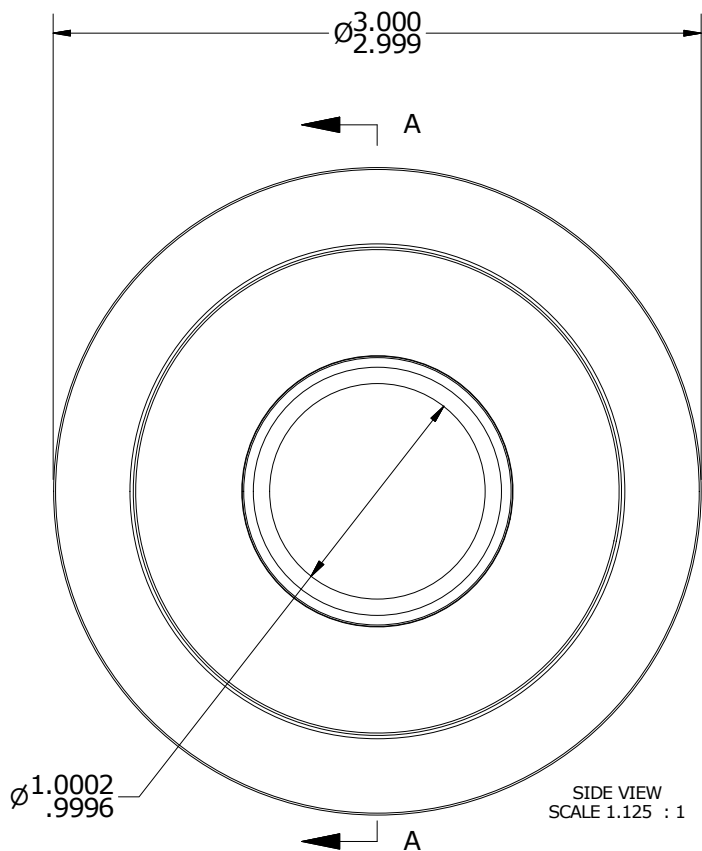
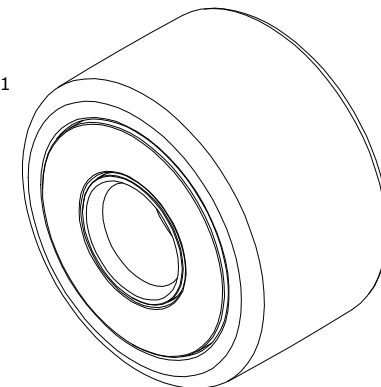

SIDE VIEW
SCALE 1.125 : 1

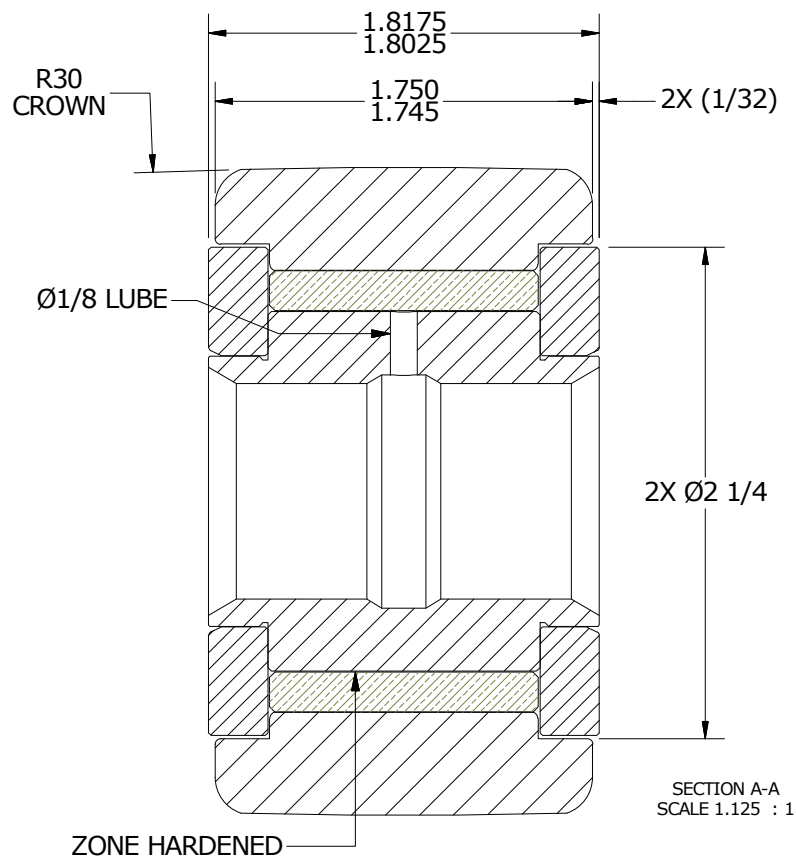

SECTION A-A
SCALE 1.125 : 1

MATERIAL NOTES:

- OUTER RING - BEARING STEEL, HEAT TREATED
- INNER RING - BEARING STEEL, ZONE HARDENED
- WASHERS - COLD ROLLED STEEL, HEAT TREATED
- BUSHING - SINTERED BRONZE

CUSTOMER PART#

XX = ± .01
XXX = ± .005
XXXX = ± .0005
ANGLES = ± 1'
INCH [METRIC]
FRACTION = ± 1/32

CARTER MANUFACTURING IS NOT RESPONSIBLE FOR TYPOGRAPHICAL ERRORS

CARTER MANUFACTURING CO., INC.

GRAND HAVEN, MICHIGAN 49417

ENGINEERING CHANGE ORDER NOTE

REVISION

PART NAME: ASSEMBLY

A

AUTHOR BY
HG

DRAWN BY
SGW

CHK'D BY
MD

SALES
KR

MATERIAL
NOTED

REVISION BY
SGW

DATE
1/2/2017

DATE
12/13/2016

DATE
12/21/2016

DATE
12/13/2016

SHEET
1 OF 2