

NOTES:

- 1. BUSHING IS IMPREGNATED WITH OIL
- 2. ALL EXPOSED STEEL SURFACES HAVE BLACK OXIDE

ISO VIEW  
SCALE .875:1

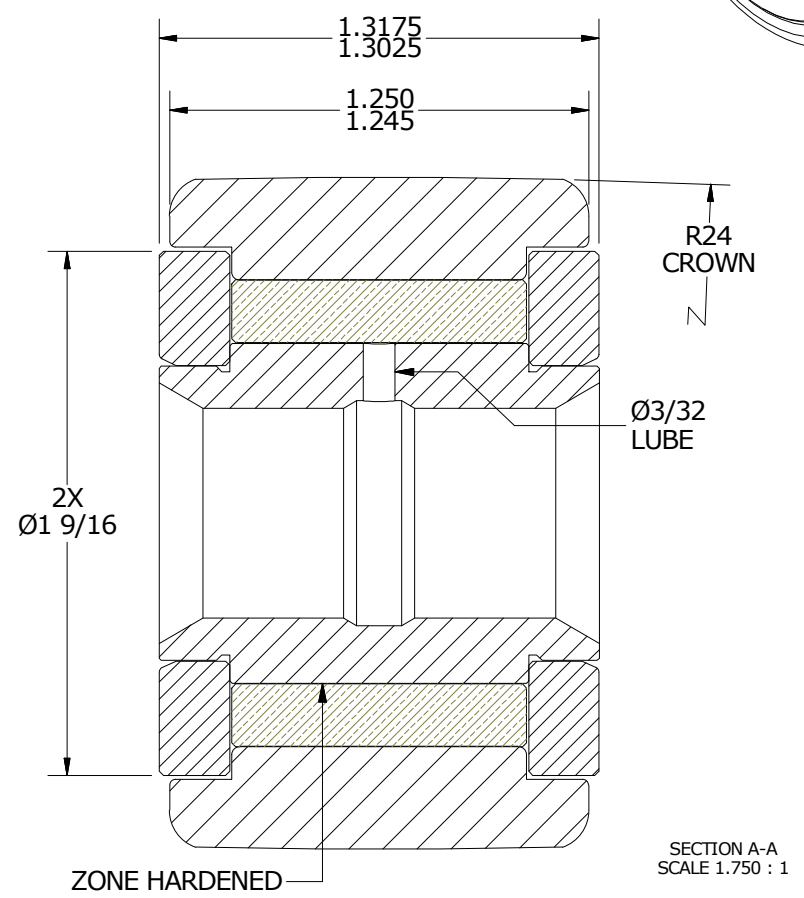
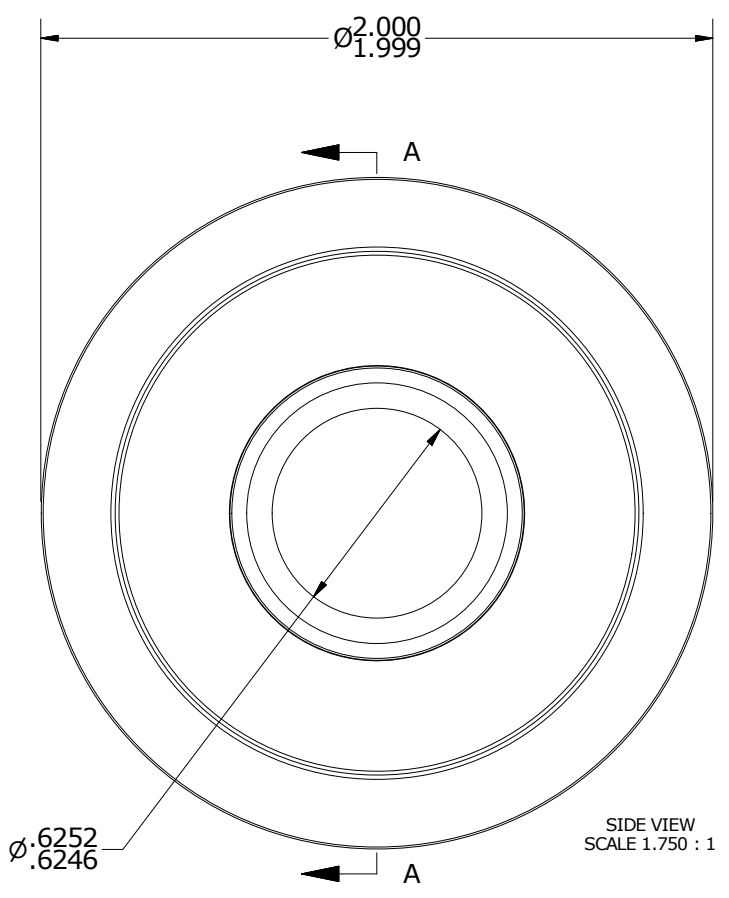
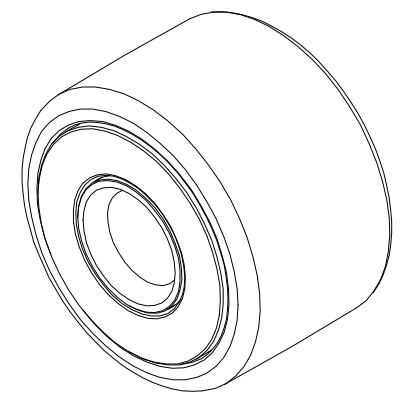

MATERIAL NOTES:

OUTER RING - BEARING STEEL, HEAT TREATED  
 INNER RING - BEARING STEEL, ZONE HARDENED  
 BUSHING - SINTERED BRONZE  
 WASHER(S) - COLD ROLLED STEEL, HEAT TREATED\*

\*(DEPENDING ON MATERIAL AVAILABILITY, MAY BE CONSTRUCTED FROM BEARING STEEL)

CUSTOMER PART#

XX = ± .01  
 XXX = ± .005  
 XXXX = ± .0005  
 ANGLES = ± 1'  
 INCH [METRIC]  
 FRACTION = ± 1/32

ENGINEERING CHANGE ORDER NOTE

CARTER MANUFACTURING IS NOT RESPONSIBLE FOR TYPOGRAPHICAL ERRORS

REVISION

<b>A</b>	AUTHOR BY HG
REVISION BY SGW	DATE 11/4/2016

**CARTER MANUFACTURING CO., INC.**  
 GRAND HAVEN, MICHIGAN 49417

PART NAME: ASSEMBLY

DRAWN BY SGW	CHK'D BY MD	SALES KR	MATERIAL NOTED
DATE 11/1/2016	DATE 11/3/2016	DATE 11/7/2016	SHEET 1 OF 2