

NOTES:  
 1. BUSHING IS IMPREGNATED WITH OIL  
 2. ALL EXPOSED STEEL SURFACES HAVE BLACK OXIDE

ISO VIEW  
 SCALE 1.125 : 1

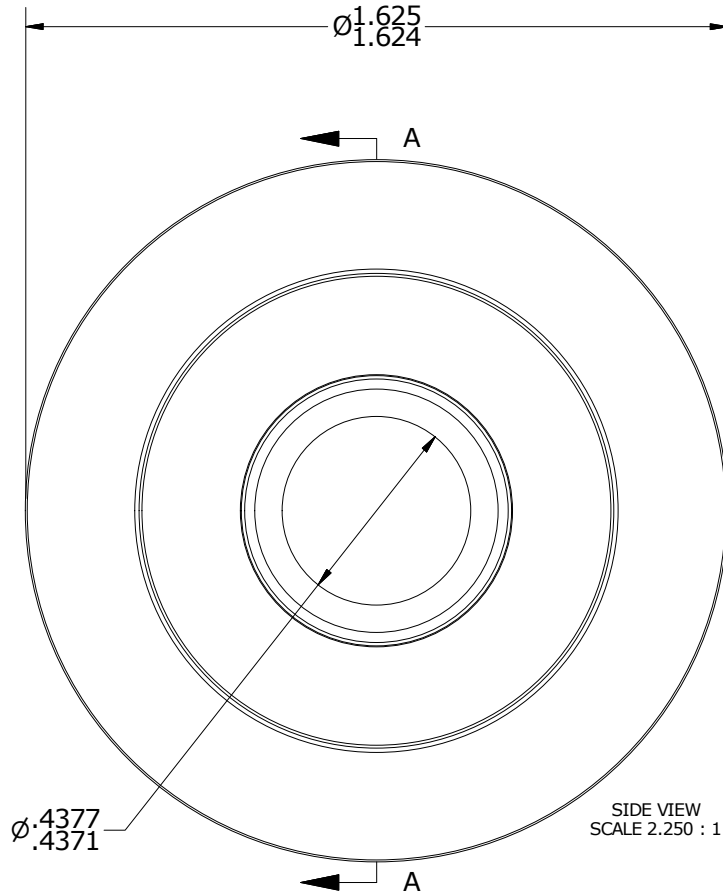

SIDE VIEW  
 SCALE 2.250 : 1

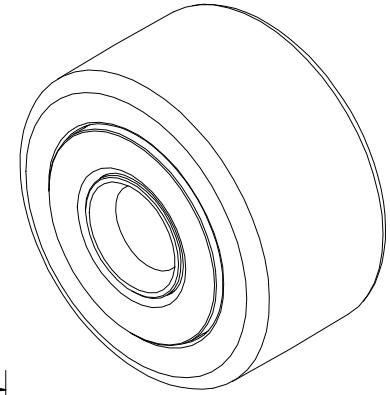
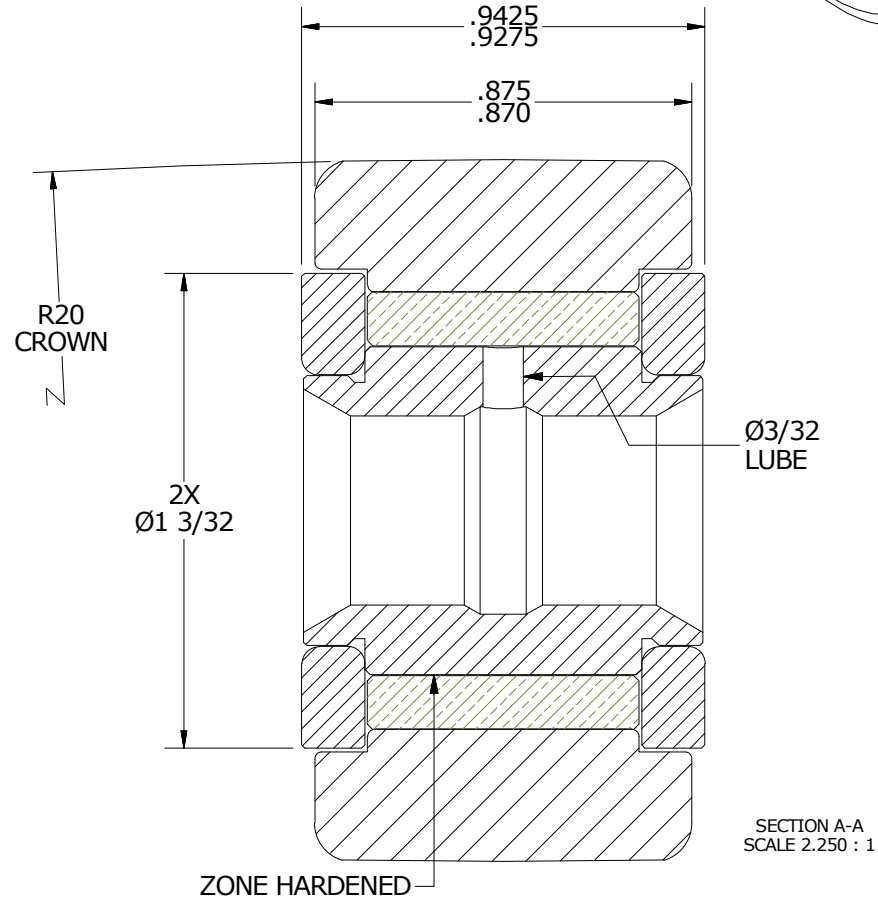

SECTION A-A  
 SCALE 2.250 : 1

MATERIAL NOTES:

OUTER RING - BEARING STEEL, HEAT TREATED  
 INNER RING - BEARING STEEL, ZONE HARDENED  
 BUSHING - SINTERED BRONZE  
 WASHER(S) - COLD ROLLED STEEL, HEAT TREATED\*

\*(DEPENDING ON MATERIAL AVAILABILITY, MAY BE CONSTRUCTED FROM BEARING STEEL)

CUSTOMER PART#

XX = ± .01  
 XXX = ± .005  
 XXXX = ± .0005  
 ANGLES = ± 1'  
 INCH [METRIC]  
 FRACTION = ± 1/32

CARTER MANUFACTURING IS NOT RESPONSIBLE FOR TYPOGRAPHICAL ERRORS

**CARTER MANUFACTURING CO., INC.**

GRAND HAVEN, MICHIGAN 49417

ENGINEERING CHANGE ORDER NOTE

REVISION

PART NAME: ASSEMBLY

<b>A</b>	AUTHOR BY	DRAWN BY	CHK'D BY	SALES	MATERIAL
	HG	SGW	MD	KR	NOTED
REVISION BY	DATE	DATE	DATE	DATE	SHEET
SGW	11/10/2016	11/8/2016	11/9/2016	11/11/2016	1 OF 2