

## NOTES:

1. BUSHING IS IMPREGNATED WITH OIL
2. ALL EXPOSED STEEL SURFACES HAVE BLACK OXIDE

ISO VIEW  
SCALE 1.750 : 1

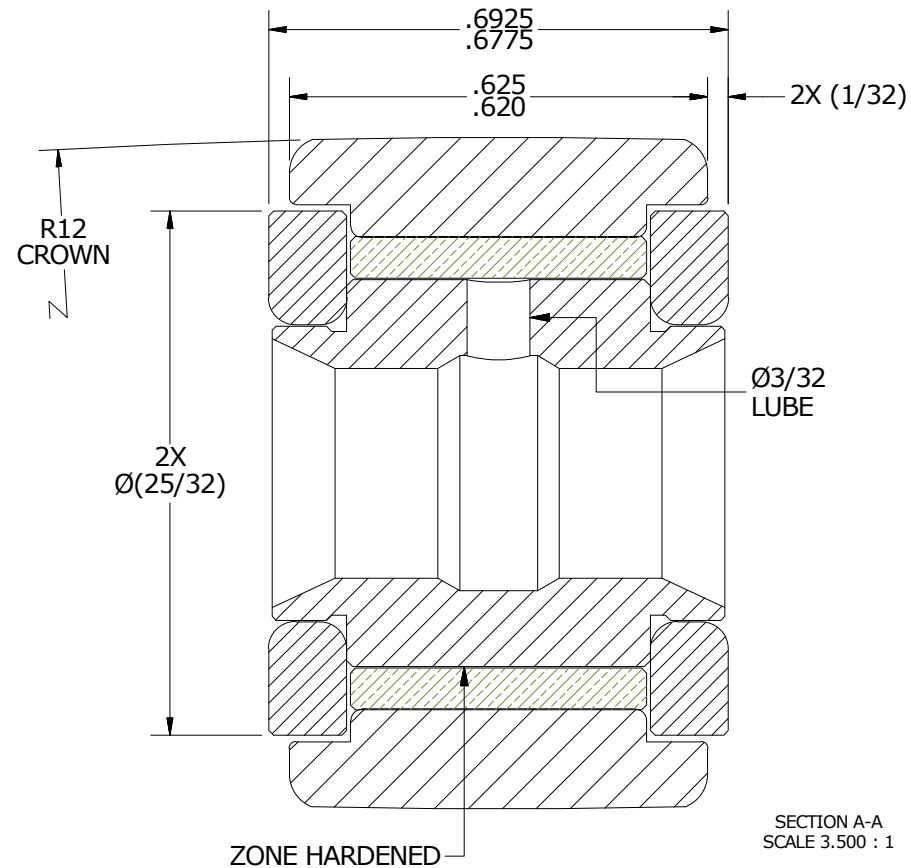
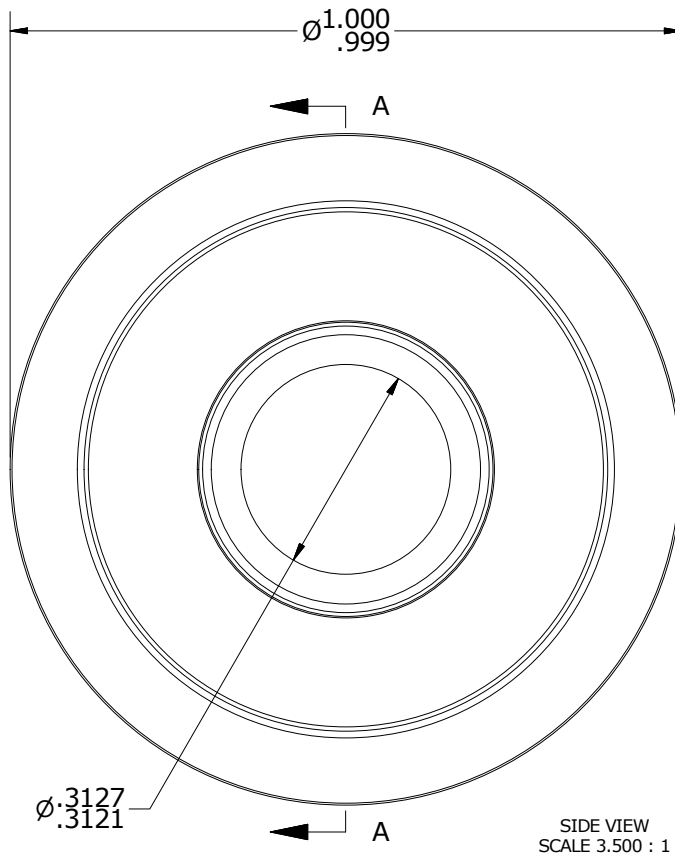
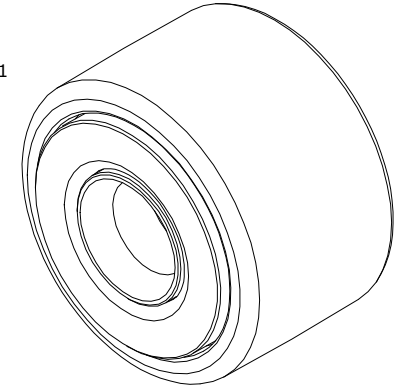

## MATERIAL NOTES:

OUTER RING - BEARING STEEL, HEAT TREATED  
INNER RING - BEARING STEEL, ZONE HARDENED  
BUSHING - SINTERED BRONZE  
WASHER(S) - BEARING STEEL, HEAT TREATED\*\*

CUSTOMER PART#

XX = ± .01  
XXX = ± .005  
XXXX = ± .0005  
ANGLES = ± 1'  
INCH [METRIC]  
FRACTION = ± 1/32

CARTER MANUFACTURING IS  
NOT RESPONSIBLE FOR  
TYPOGRAPHICAL ERRORS

**CARTER MANUFACTURING CO., INC.**

GRAND HAVEN, MICHIGAN 49417

REVISION

PART NAME: ASSEMBLY

ENGINEERING CHANGE ORDER NOTE

A

AUTHOR BY

DRAWN BY

CHK'D BY

SALES

MATERIAL

HG

SGW

MD

KR

NOTED

REVISION BY

DATE

DATE

DATE

DATE

SHEET

SGW

1/2/2017

12/14/2016

12/21/2016

12/21/2016

1 OF 2