

- NOTES:**  
 1. BEARING IS PACKED WITH GREASE  
 2. ALL EXPOSED SURFACES ARE BLACK OXIDED

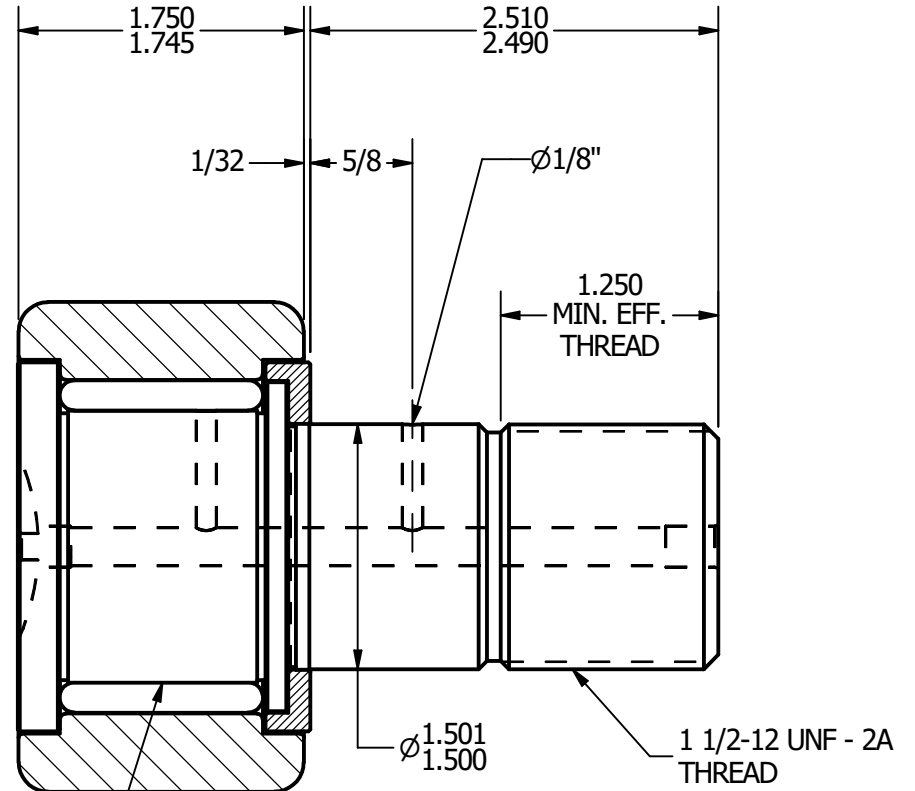
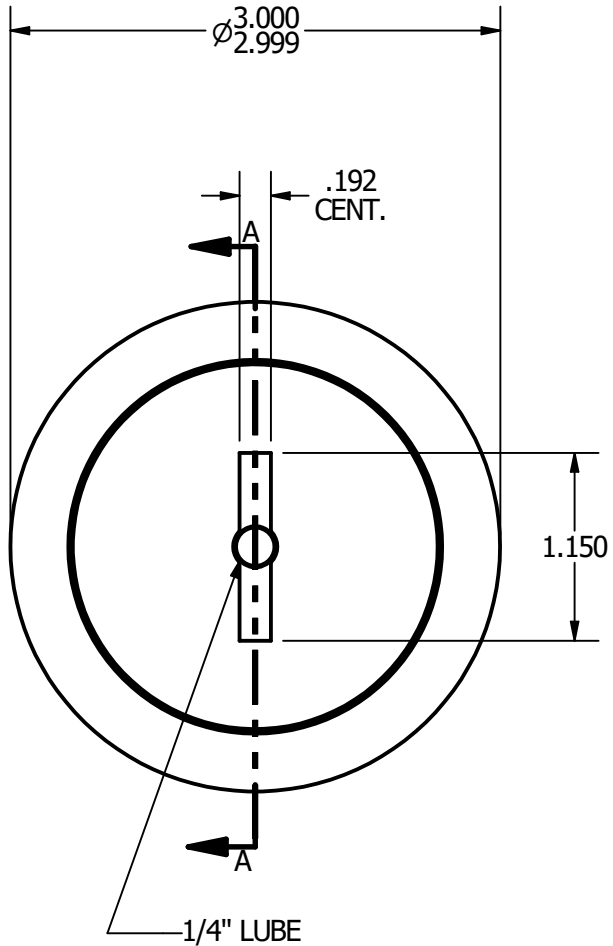
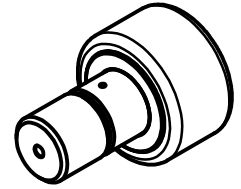

**RADIAL BASIC DYNAMIC RATING (POUNDS) 15,720**

**MAXIMUM STATIC CAPACITY (POUNDS) 49,820**

**MATERIAL NOTES:**  
 OUTER - BEARING STEEL, HEAT TREATED  
 STUD - BEARING STEEL, ZONE HARDENED  
 ROLLER - BEARING STEEL, HEAT TREATED  
 WASHER - COLD ROLLED STEEL, HEAT TREATED

CUSTOMER PART#  
 .XX = ± .01  
 .XXX = ± .005  
 .XXXX = ± .0005  
 ANGLES = ± 1'  
 INCH [METRIC]

CARTER MANUFACTURING IS NOT RESPONSIBLE FOR TYPOGRAPHICAL ERRORS

**CARTER MANUFACTURING CO., INC.**

GRAND HAVEN, MICHIGAN 49417

REVISION

PART NAME: Assembly

SHEET 1 OF 2

**A**

REV. BY

JAF

AUTHOR. BY

JGV

DATE

7/10/2006

DRAWN BY

JAF

DATE

7/10/2006

CHK'D BY

JGV

DATE

7/10/2006

SALES

KPR

DATE

7/10/2006

MATERIAL

NOTED

DRAWING NO.

CNBH-96