

NOTES:
1. BEARING IS PACKED WITH GREASE
2. ALL EXPOSED SURFACES ARE BLACK OXIDED

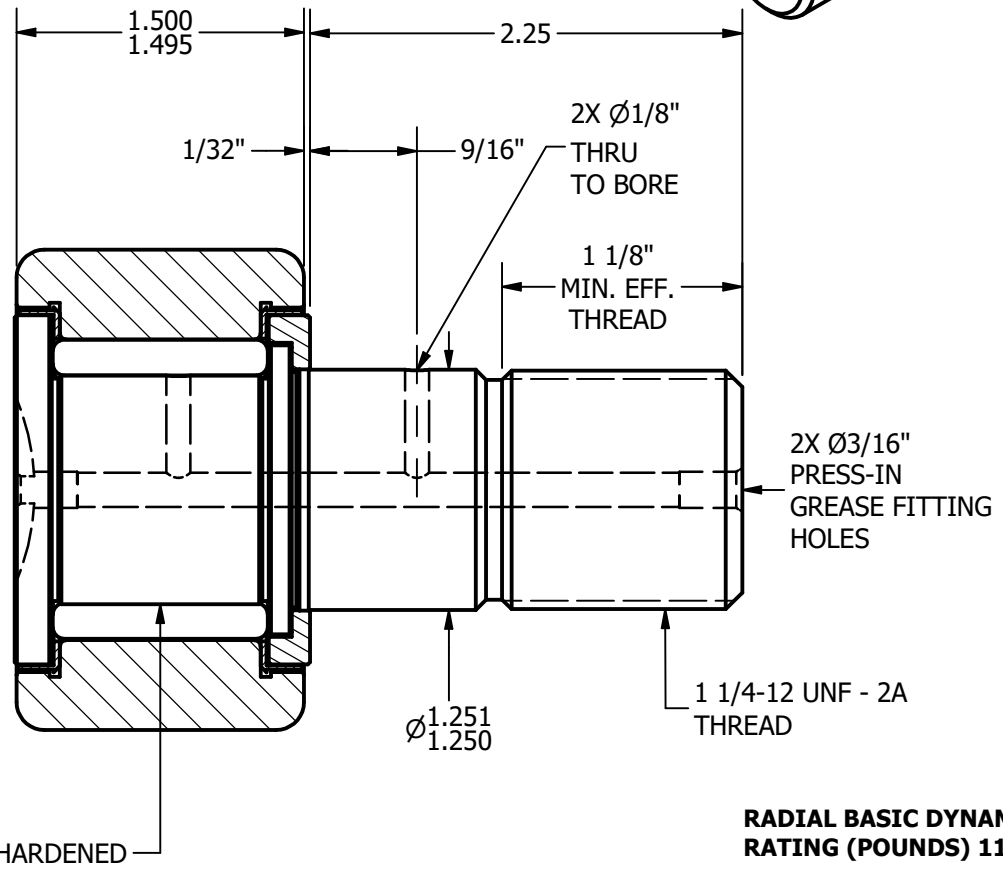
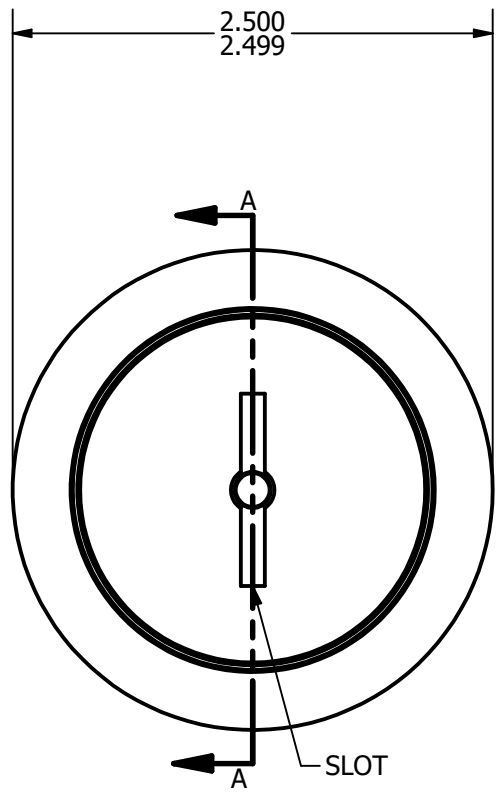
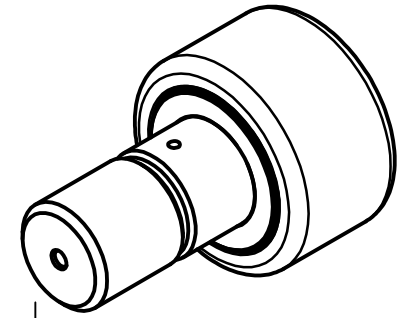

RADIAL BASIC DYNAMIC RATING (POUNDS) 11,720
MAXIMUM STATIC CAPACITY (POUNDS) 32,900

MATERIAL NOTES:
OUTER - BEARING STEEL, HEAT TREATED
STUD - BEARING STEEL, ZONE HARDENED
ROLLERS - BEARING STEEL, HEAT TREATED
WASHER - COLD ROLLED STEEL, HEAT TREATED
SEALS - SYNTHETIC

<i>CUSTOMER PART#</i>	.XX = ± .01 .XXX = ± .005 .XXXX = ± .0005 ANGLES = ± 1° INCH [METRIC]
CHANGE NOTE:	

CARTER MANUFACTURING IS NOT RESPONSIBLE FOR TYPOGRAPHICAL ERRORS

REVISION	
A	<i>AUTHOR. BY</i>
JAF	JGV
<i>REV. BY</i>	<i>DATE</i>
JAF	7/11/2006

CARTER MANUFACTURING CO., INC.
 GRAND HAVEN, MICHIGAN 49417

PART NAME: Assembly			SHEET 1 OF 2		
<i>DRAWN BY</i>	<i>CHK'D BY</i>	<i>SALES</i>	<i>MATERIAL</i>		
JAF	JGV	KPR	NOTED		
<i>DATE</i>	<i>DATE</i>	<i>DATE</i>	<i>DRAWING NO.</i>		
7/11/2006	7/11/2006	7/10/2006	CNBH-80-S		