

LOAD RATINGS		
RATING	lbf	Newtons
RADIAL BASIC DYNAMIC	8,090	35,896
MAXIMUM STATIC CAPACITY	21,140	94,035

RECOMMENDED MOUNTING HOLE Ø		
Limit	Inch	mm
MIN	1.1250	28.5750
MAX	1.1255	28.5877

MAXIMUM CLAMPING TORQUE		
Thread Type	Inch Lbs	Nm
DRY	2,800	316
LUBRICATED	1,400	158

- NOTES:
- BEARING IS PACKED WITH NLGI GRADE 2, LITHIUM BASED GREASE (UNLESS OTHERWISE SPECIFIED)
 - ALL EXPOSED STEEL SURFACES HAVE BLACK OXIDE
 - LIMITING SPEED:
 - A. GREASE = 1,400 RPM

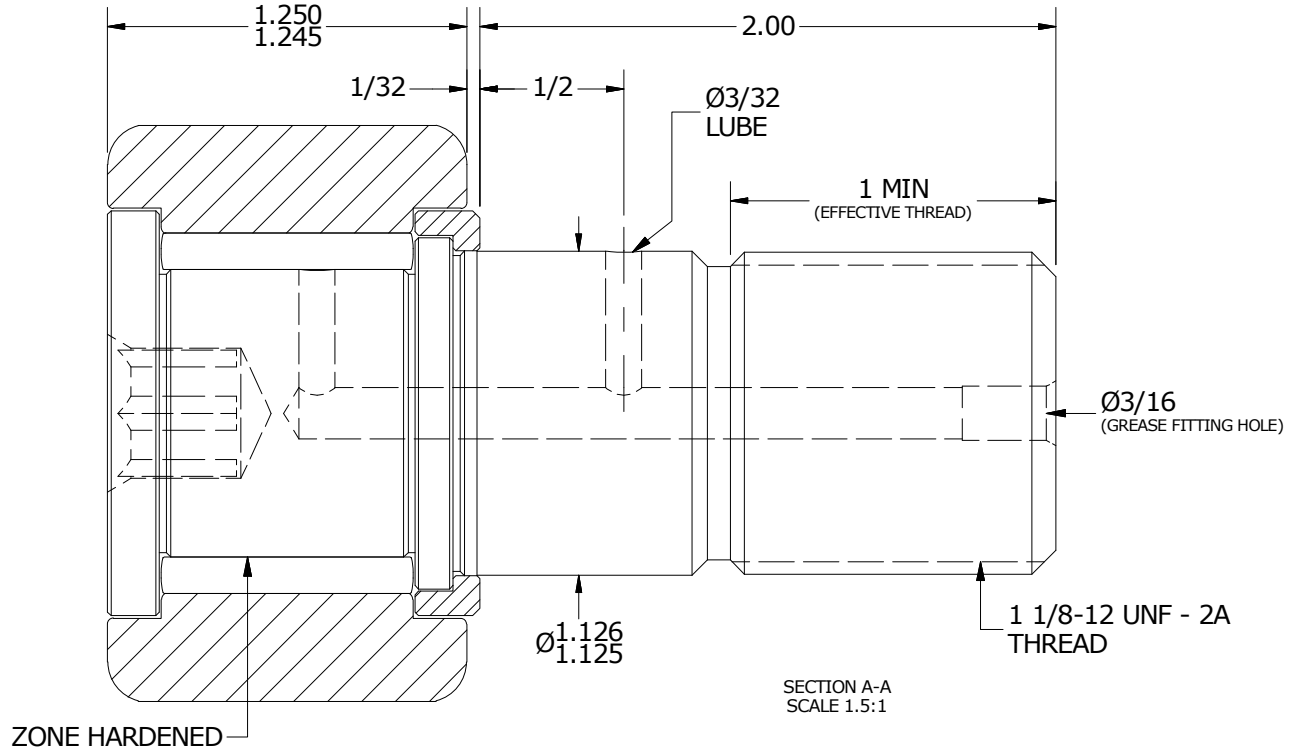
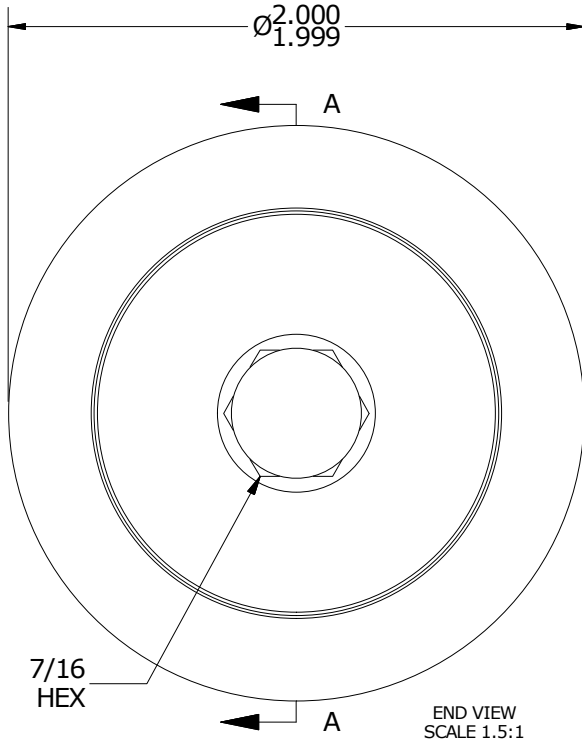
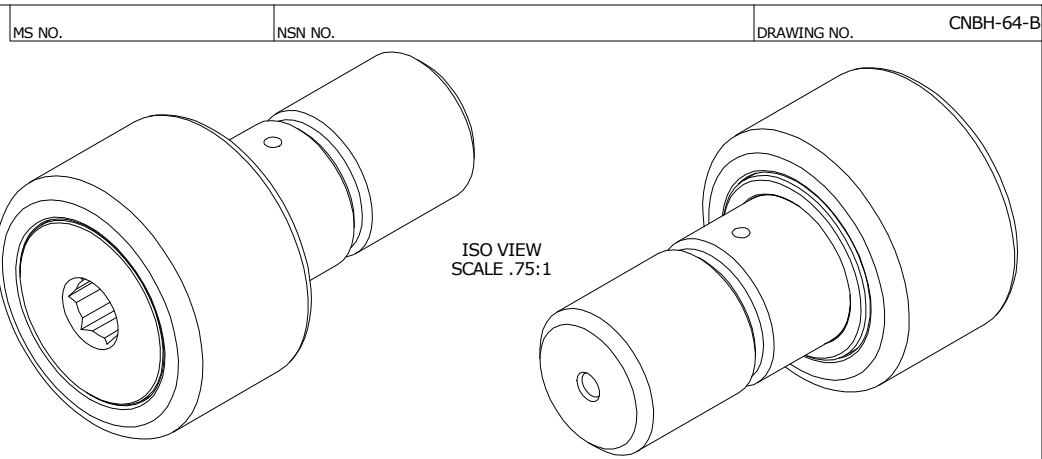

MATERIAL NOTES:

OUTER RING - BEARING STEEL, HEAT TREATED
 STUD - BEARING STEEL, ZONE HARDENED
 NEEDLE ROLLER(S) - BEARING STEEL, HEAT TREATED
 WASHER - BEARING STEEL, HEAT TREATED

CUSTOMER PART#
 XX = ± .01
 XXX = ± .005
 XXXX = ± .0005
 ANGLES = ± 1'
 INCH [METRIC]
 FRACTION = ± 1/32

CARTER MANUFACTURING IS NOT RESPONSIBLE FOR TYPOGRAPHICAL ERRORS

CARTER MANUFACTURING CO., INC.
 GRAND HAVEN, MICHIGAN 49417

ENGINEERING CHANGE ORDER NOTE

REVISION		PART NAME: ASSEMBLY			PRODUCT TYPE: CNB	
B	AUTHOR BY HG	DRAWN BY JAF	CHK'D BY MD	SALES KR	MATERIAL NOTED	
REVISION BY SGW	DATE 7/17/2018	DATE 7/12/2006	DATE 7/17/2018	DATE 7/17/2018	SHEET 1 OF 2	