

LOAD RATINGS		
RATING	lbf	Newtons
RADIAL BASIC DYNAMIC	2,225	9,897
MAXIMUM STATIC CAPACITY	6,120	27,223

RECOMMENDED MOUNTING HOLE Ø		
Limit	Inch	mm
MIN	.6250	15.8750
MAX	.6255	15.8877

MAXIMUM CLAMPING TORQUE		
Thread Type	Inch Lbs	Nm
DRY	650	73
LUBRICATED	325	36.5

- NOTES:
1. BEARING IS PACKED WITH NLGI GRADE 2, LITHIUM BASED GREASE (UNLESS OTHERWISE SPECIFIED)
 2. ALL EXPOSED STEEL SURFACES HAVE BLACK OXIDE
 3. CUSTOM LASER ETCHING UPON REQUEST
 4. LIMITING SPEED:
 - A. GREASE = 3,400 RPM

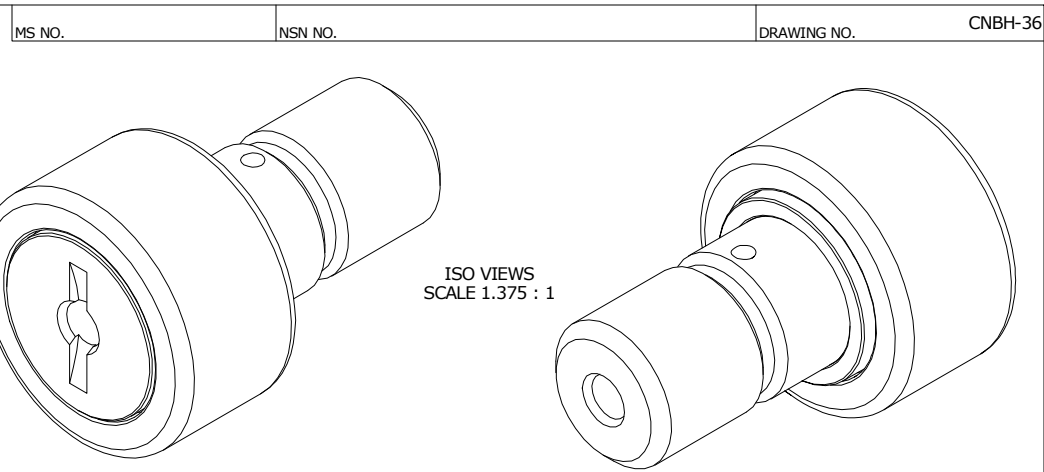

ISO VIEWS
SCALE 1.375 : 1

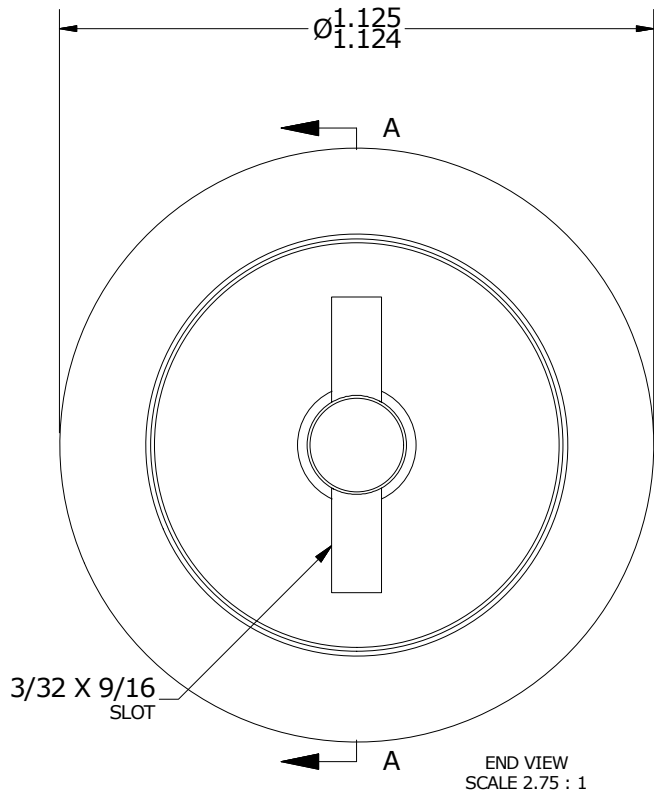

END VIEW
SCALE 2.75 : 1

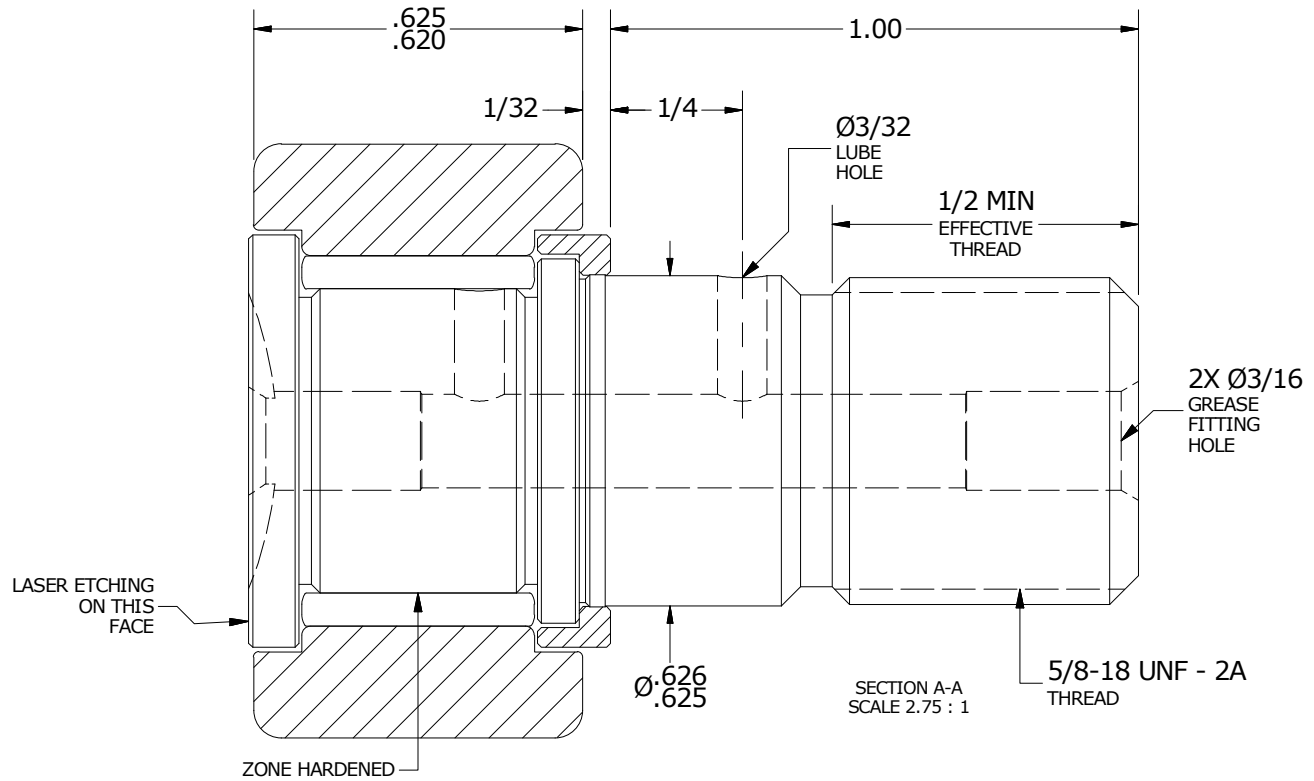

SECTION A-A
SCALE 2.75 : 1

MATERIAL NOTES:

- OUTER RING - BEARING STEEL, HEAT TREATED
- STUD - BEARING STEEL, ZONE HARDENED
- NEEDLE ROLLER(S) - BEARING STEEL, HEAT TREATED
- WASHER - BEARING STEEL, HEAT TREATED

CUSTOMER PART#	XX = ± .01 XXX = ± .005 XXXX = ± .0005 ANGLES = ± 1' INCH [METRIC] FRACTION = ± 1/32
ENGINEERING CHANGE ORDER NOTE	

CARTER MANUFACTURING IS NOT RESPONSIBLE FOR TYPOGRAPHICAL ERRORS

CARTER MANUFACTURING CO., INC.
GRAND HAVEN, MICHIGAN 49417

REVISION		PART NAME: ASSEMBLY			PRODUCT TYPE: CNB	
B	AUTHOR BY DB	DRAWN BY EMD	CHK'D BY MD	SALES KR	MATERIAL NOTED	
REVISION BY SGW	DATE 5/6/2013	DATE 6/27/2006	DATE 5/6/2013	DATE 5/6/2013	SHEET 1 OF 2	